

All-Weather Windscreen WS-15 Instruction Manual

Mounting the WS-15

To mount the all-weather windscreen WS-15, perform the steps described below. The preamplifier, microphone, tripod, extension cable EC-04 series, and mounting adapter for windscreen are all available as options. Before using equipment such as the sound level meters and preamplifiers, carefully read the instruction manual for each device. The preamplifier models that can be mounted on the WS-15 are as follows: NH-21, NH-23, NH-24, NH-25, and NH-26.

1. Attach the mounting stage for microphone to the tripod.

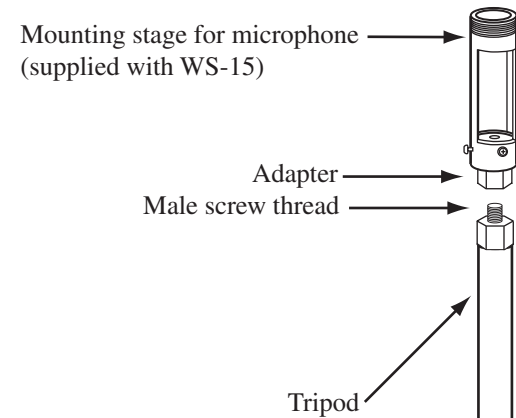

2. Insert the extension cable EC-04 series through the side of the mounting stage for microphone.

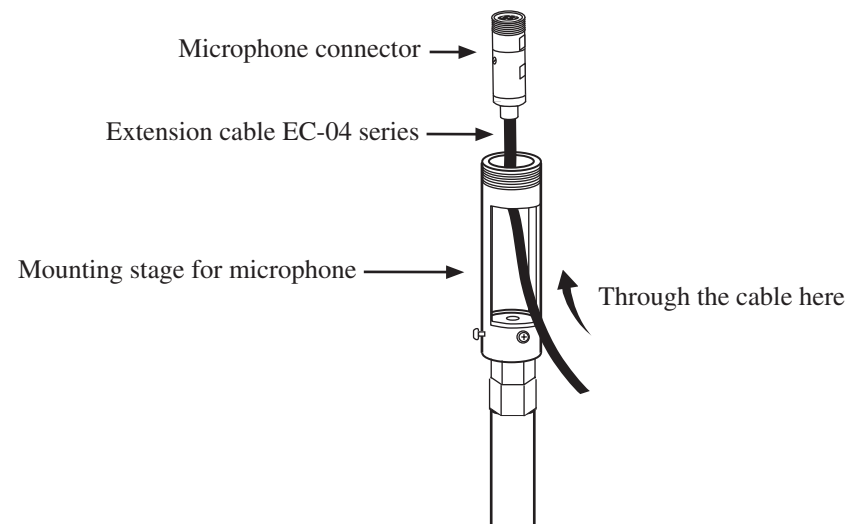

3. Connect the extension cable EC-04 series to the preamplifier.

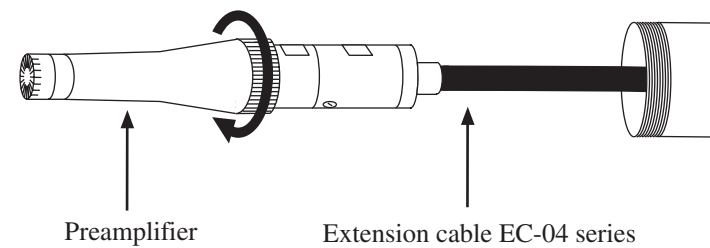

Note

Remove the windscreen fall prevention rubber from the preamplifier. If the rubber is attached to the preamplifier, the WS-15 cannot be mounted.

4. Attach the mounting adapter for windscreen.

The mounting adapter for windscreen has a slit along the side. To attach the adapter, slide the cable section of the extension cable EC-04 series through the opening. For this step, it is important to note that the direction in which you insert the mounting adapter for the windscreen differs according to the preamplifier model you are using.

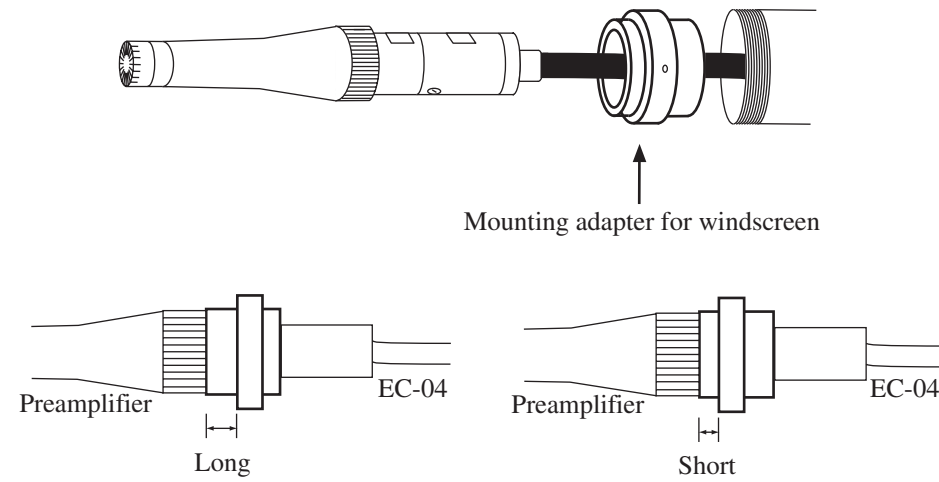

When attaching the NH-21, NH-24, NH-25 and NH-26

When attaching the NH-23

5. Insert the preamplifier into the mounting stage for microphone from the top.

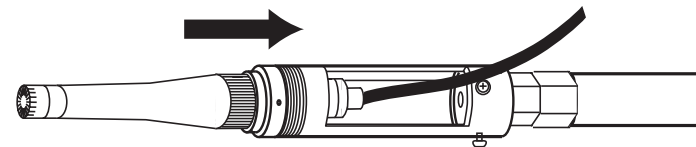

6. Insert the preamplifier into the base of the WS-15 and rotate the base to securely fasten it to the mounting tube. Then, insert the inner cap through the wires of the base and cover the preamplifier with the inner cap firmly. While doing this, take care that the tips of the springs attached to the base do not come into contact with the microphone.

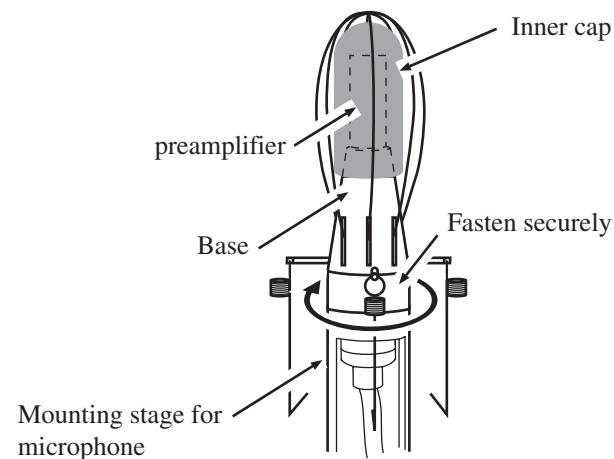

Important

Be aware that if you put the windscreen and the base together beforehand, the inner cap may be displaced and the preamplifier may not fit into the inner cap.

7. Mount the windscreen.

In the lower part of the windscreen, there are three slits. Align these slits with the hooks on the base and push the windscreen fully onto the base.

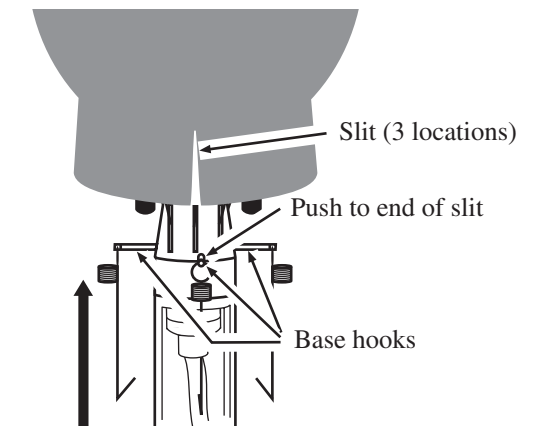

8. Push the tips of the springs attached to the hooks firmly into the windscreen, at about the middle section.

