

INSTRUCTION MANUAL

INTERFACE UNIT

UV-22



3-20-41 Higashimotomachi, Kokubunji, Tokyo 185-8533, Japan

<https://www.rion.co.jp/english/>

Organization of this manual

This manual describes the features, operation, and other aspects of the Interface Unit UV-22. If the unit is used together with other equipment to configure a measurement system, consult the documentation of all other components as well. The section starting on page iii contains important information about safety. Be sure to read and observe these precautions in full.

This manual contains the following sections.

Outline

Gives basic information about the unit.

Names of Parts and Functions

Briefly identifies and explains the front panel controls, rear panel connectors and all other parts of the unit.

Linking

Explains how to configure multiple units as a system.

Power Supply Connection

Explains how to make connections for powering the unit.

Preparations

Explains the procedure for communication with a computer (via USB or Ethernet) and the procedure for installing the USB driver.

Commands

Explains the communication protocol and sequence, and provides a definition of all commands.

Supplied CD-ROM

Explains the contents of the supplied CD-ROM.

Specifications

Lists the technical specifications of the unit.

Reference Material

Provides an explanation of maintenance parts.

- * Company names and product names mentioned in this manual are usually trademarks or registered trademarks of their respective owners.

FOR SAFETY

In this manual, important safety instructions are specially marked as shown below. To prevent the risk of death or injury to persons and severe damage to the unit or peripheral equipment, make sure that all instructions are fully understood and observed.



Disregarding instructions printed here incurs the risk of death or severe injury to persons.

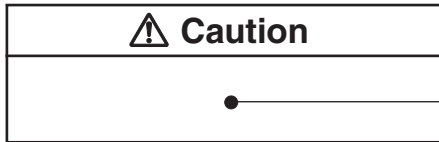

Disregarding instructions printed here incurs the risk of injury to persons and/or damage to peripheral equipment.



Disregarding instructions printed here incurs the risk of damage to the product.

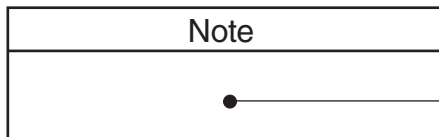

Additional information about using the unit. (These notes do not directly affect safety.)

This product can be used in any areas including residential areas.



The product described in this manual is in conformity with the following standards;

Electrical equipment for measurement control and laboratory use.

RION Co., Ltd.

3-20-41 Higashimotomachi, Kokubunji, Tokyo 185-8533, Japan

Precautions

- Operate the unit only as described in this manual.
- Do not disassemble the unit or attempt internal alterations.
- Observe the following precautions before using the unit:
 - Make sure that all connections are properly and safely established.
 - Make sure that the unit is operating normally.
- The permissible ambient temperature range for operation of the unit is -10°C to $+50^{\circ}\text{C}$. Relative humidity must be 90% or below.
- The power cord used to connect the optional AC adapter to an AC outlet is a 100 V AC cord for domestic use in Japan, which is compliant with Japanese laws and electrical safety standards. Do not use this power cord outside Japan or with any voltage other than 100 V AC. Otherwise, RION cannot guarantee the safety of the equipment. Use a power cable that is compliant with the laws and electrical safety standards of your location.
- If you notice any sign of a problem during use, disconnect the AC adapter or battery unit, and contact your supplier.
- Do not use or store the unit in locations which
 - may be subject to strong magnetic fields or strong radiation, or
 - may be subject to high levels of dust or splashes of water, or
 - may be subject to gases or air with high salt or sulphur content, or are in the vicinity of stored chemicals, or
 - may be subject to high temperature, humidity, or to direct sunlight, or
 - may be subject vibrations or shock.
- Always switch off the power after using the unit.
- When disconnecting cables, always hold the plug and do not pull the cable.
- Use only the specified AC adapter or other specified power source.
- This is a precision device. Take care not to drop the unit and protect it from shocks.
- In case of malfunction, do not attempt any repairs. Note the condition of the unit clearly and contact the supplier.
- When disposing of the unit, follow national and local regulations regarding waste disposal.

Contents

Precautions.....	v
Outline.....	1
Names of Parts and Functions.....	3
Front Panel.....	3
Rear panel.....	5
Top panel.....	6
Bottom panel.....	6
Linking.....	7
Linking procedure.....	8
Removing the cable from the link connector.....	12
Power Supply Connection.....	13
Preparations.....	14
Setting the ID number.....	14
LOCAL (MASTER/SLAVE).....	16
Master/Slave Operation.....	17
Master/Slave operation for calibration.....	17
Master/Slave operation for setup.....	18
Master/Slave operation for numeric readout switching.....	18
Communication.....	19
LAN connection.....	20
Installing the USB driver.....	21
Installation procedure.....	22
Ethernet setup.....	27

Commands	30
Transfer method and sequence	30
Transfer codes	30
Transfer format	31
Block reception processing	33
Command types	33
Error processing	33
Transfer sequence	34
Ratings	40
Guaranteed values	40
Rated values	40
Commands	41
Command Format	42
Command Reference	44
Getting measurement values	56
Measurement value data format	57
Supplied CD-ROM.....	60
Specifications	61
Rack Mounting Base	64
Reference Material	65
Maintenance parts	65
User Filter	66

Outline

The UV-22 is a dedicated interface unit for use with the Sound Level Meter Unit UN-14 and Vibration Meter Unit UV-15. Up to 16 UN-14 and UV-15 units can be linked to a single UV-22. Both USB and Ethernet (LAN) interfaces are provided for connection of the UV-22 to a computer, allowing setup, measurement control, and data retrieval for the UN-14 and UV-15 from the computer.

The supplied UV-22Viewer software makes it easy to establish settings for the UN-14 and UV-15 and display measurement results on the computer. User filter settings *1 for the UN-14/UV-15 can also be made.

The Master/Slave function *2 of the UN-14/UV-15 is supported as well, which simplifies operation of multiple units.

*1 User filter

One cutoff frequency as specified below can be added by the user to the factory default high-pass filter and low-pass filter settings of the UN-14/UV-15.

Cutoff frequency (UV-15: -10% attenuation, UN-14: -3 dB attenuation)

HPF: 3 Hz, 3.15 Hz, 4 Hz, 5 Hz, 6.3 Hz, 8 Hz, 10 Hz, 12.5 Hz, 15 Hz, 16 Hz, 20 Hz, 25 Hz, 30 Hz, 31.5 Hz, 40 Hz, 50 Hz, 63 Hz, 80 Hz, 100 Hz, 125 Hz, 150 Hz, 160 Hz.

Attenuation slope: -18 dB/oct

LPF: 300 Hz, 315 Hz, 400 Hz, 500 Hz, 630 Hz, 800 Hz, 1 kHz, 1.25 kHz, 1.5 kHz, 1.6 kHz, 2 kHz, 2.5 kHz, 3 kHz, 3.15 kHz, 4 kHz, 5 kHz, 6.3 kHz, 8 kHz, 10 kHz, 12.5 kHz, 15 kHz, 16 kHz, 20 kHz (25 kHz, 31.5 kHz, 40 kHz, 50 kHz).

Settings in brackets are for UN-14 only.

Attenuation slope: -18 dB/oct

Frequency response characteristics for the high-pass filter and low-pass filter are shown in the “Reference Material” section (from page 66).

*2 Master/Slave function

When multiple UN-14 or UV-15 units are linked, the settings of other units (Slave units) can be changed from one unit (Master unit) using this function.

For example, if you set one UN-14 (Master unit) to CAL (calibration) mode using a special key action, all other UN-14 units (Slave units) will also go into calibration mode. (To do this, you simply need to press and hold the CAL key on the unit you want to use as Master unit.)

The following optional equipment is available.

- Sound Level Meter Unit UN-14
Single-channel sound level meter unit supporting the connection of a measurement microphone with preamplifier.

- Vibration Meter Unit UV-15
Single-channel vibration meter unit supporting the connection of an accelerometer.

Names of Parts and Functions

Front Panel

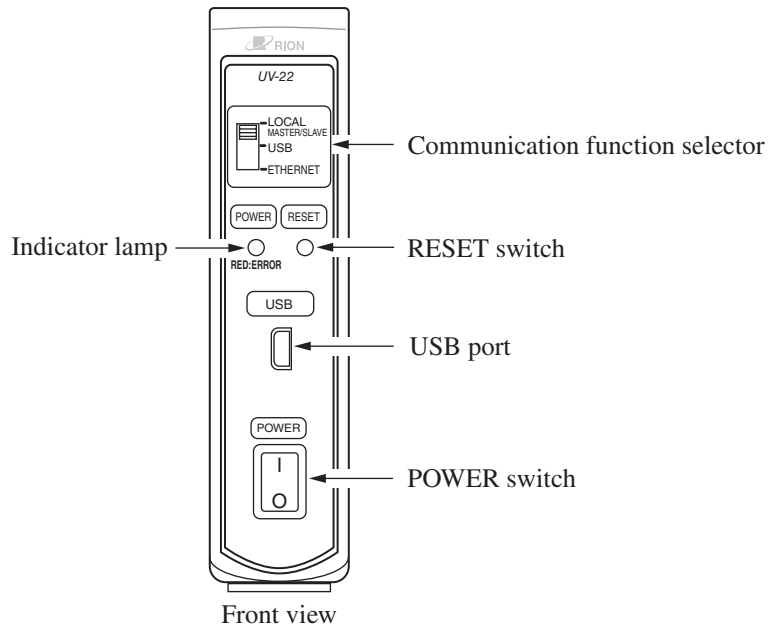

Communication function selector

LOCAL (MASTER/SLAVE)

Select this position when the linked UN-14/UV-15 units are not to be controlled via a USB or Ethernet connection but by their own switches and operation keys.

USB:

Select this position to use the USB interface for communication.

Ethernet:

Select this position to use the Ethernet (LAN) interface for communication.

RESET switch

Pressing this switch resets the UV-22 as well as linked UN-14/UV-15 units and performs a restart. Use this in case of a communication problem.

USB port

To use USB for the connection to a computer, plug the USB cable into this connector.

The connector on the cable must be a mini-B type.

If using USB for the first time, the USB driver must be installed on the computer.

POWER switch

Set to ON to activate the unit.

If an AC adapter is connected to the UV-22, setting the POWER switch to ON will also supply power to the linked UN-14/UV-15 units.

When using the Battery Unit BP-17, connect the AC adapter to the BP-17 and leave the POWER switch of the UV-22 set to ON. Power on/off then is controlled with the power switch of the BP-17.

Indicator lamp

This LED indicator shows power on/off status, initialization, and error information.

LED flashes green: Initialization in progress
Communication commands cannot be received.

LED light in green: Unit operative, send/receive enabled.

LED light in red or flashing in red:
Error has occurred.

LED off: Power is off.

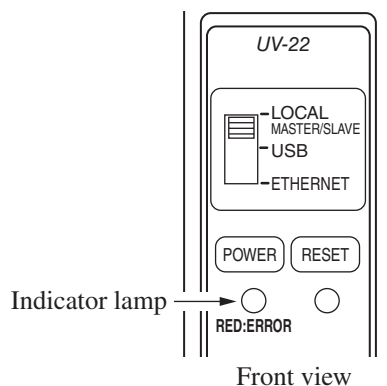

Rear panel

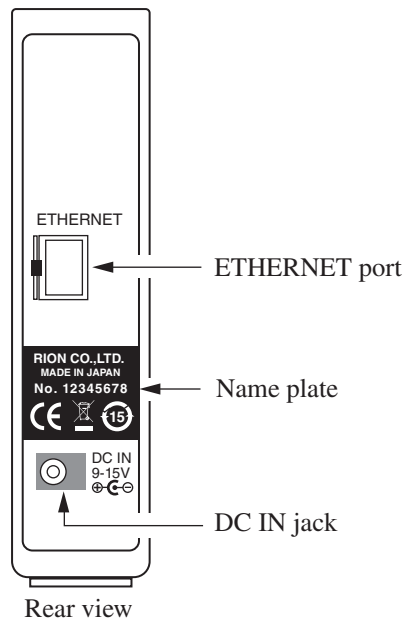

ETHERNET port

The LAN cable for Ethernet connection must be plugged in here.

Name plate

Shows the serial number and other information about the unit.

DC IN jack

The optional AC adapter NC-99 series or an external DC power supply can be connected here.

Top panel

The top panel of the unit has two hooks which can be used to join multiple units together.

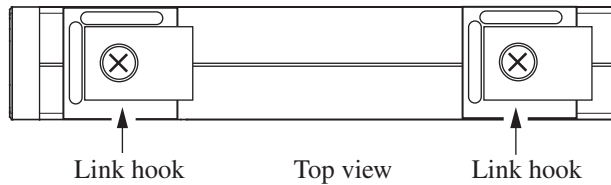

Bottom panel

Removing the cover plates on the bottom of the unit gives access to a connector that is used to supply power and for signal transfer when linking UN-14/UV-15 units.

Use the link plate supplied with the UN-14/UV-15 to join multiple units.

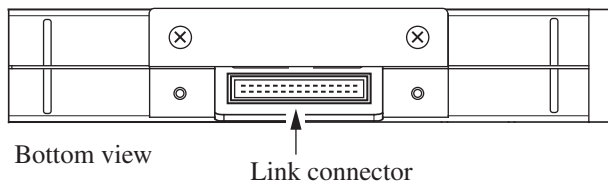

Linking

Install the Interface Unit UV-22 in the leftmost position of a linked series of units as seen from the front.

Required tool:

Phillips screwdriver (JIS B 4633:1998, type H, No. 2)

Important

Precautions for linking units

- Make sure that power is OFF before starting:
 - Disconnect AC adapter.
 - When using Battery Unit BP-17: Remove batteries
- Do not use any screws other than the ones supplied with the product.
- Do not insert any objects (pieces of metal, pencil lead, etc.) into the unit.
- Use only the specified screwdriver (Phillips screwdriver, JIS B 4633:1998, type H, No. 2). Otherwise the cross-shaped slots on the screw heads may be damaged.

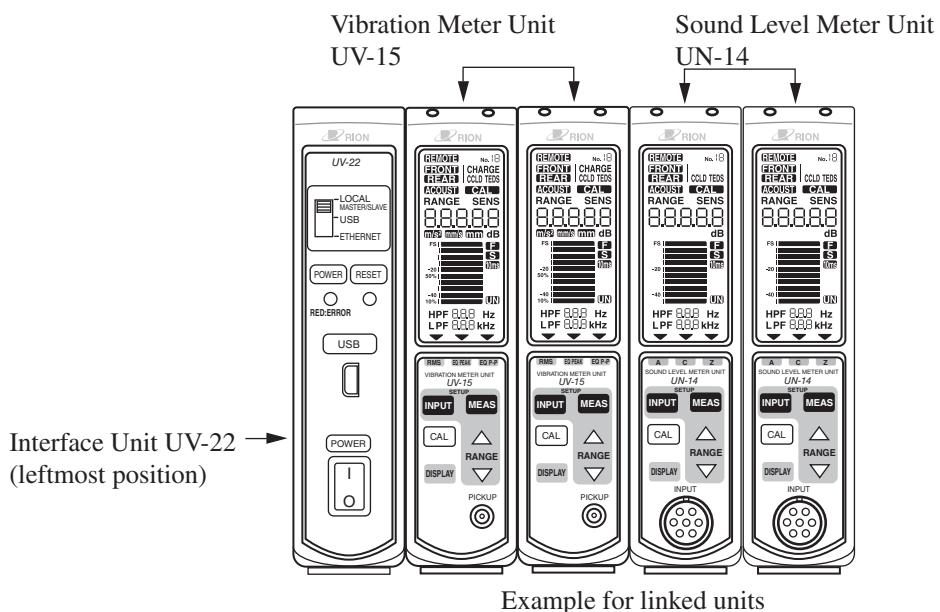

Linking procedure

1. Remove the two link hooks on the top panel. Do not remove these hooks for the unit that will be the rightmost unit as seen from the front.

Put the screws and hooks in a box or other suitable container, to make sure that you do not lose any parts. The parts will be required later for reassembly.

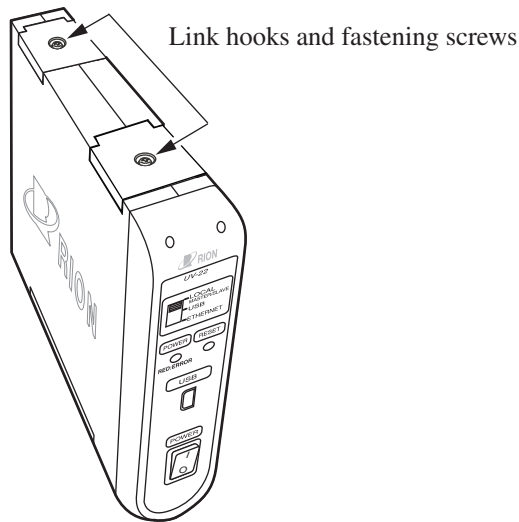

2. Plug the link connector of each unit into the link connector of the next unit.

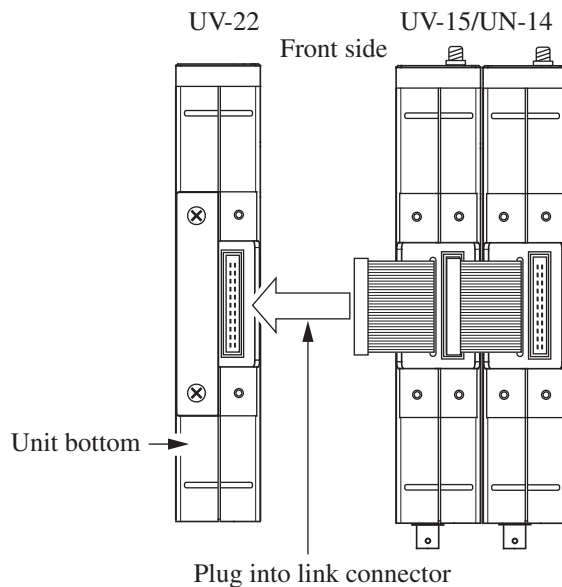

- After plugging in the link connectors, use the link plates supplied with the UN-14/UV-15 and the screws removed in step 1 to provisionally join the units as shown below.

Be sure to use the screws removed in step 1.

Why not to use other screws:

Too short screws will not properly secure the plate.

Too long screws may damage parts inside the unit.

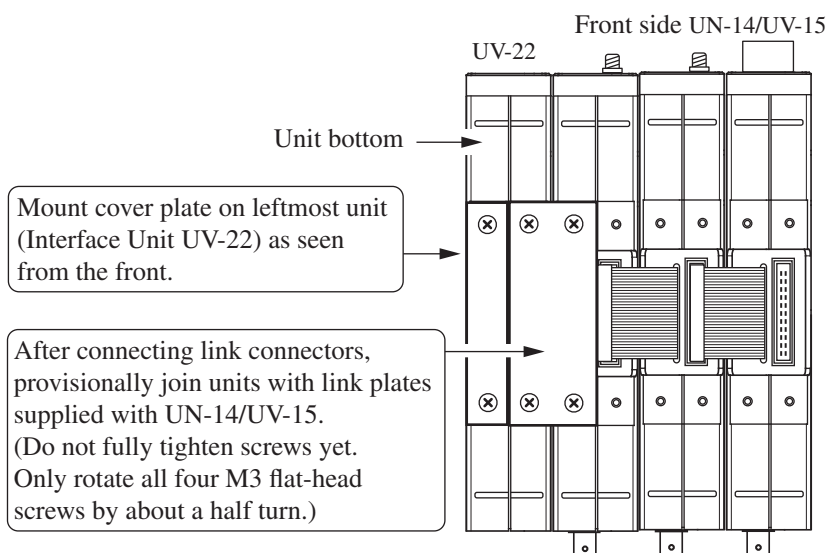

- Attach the link hooks removed in step 1 to the unit tops, so that the units are locked together.

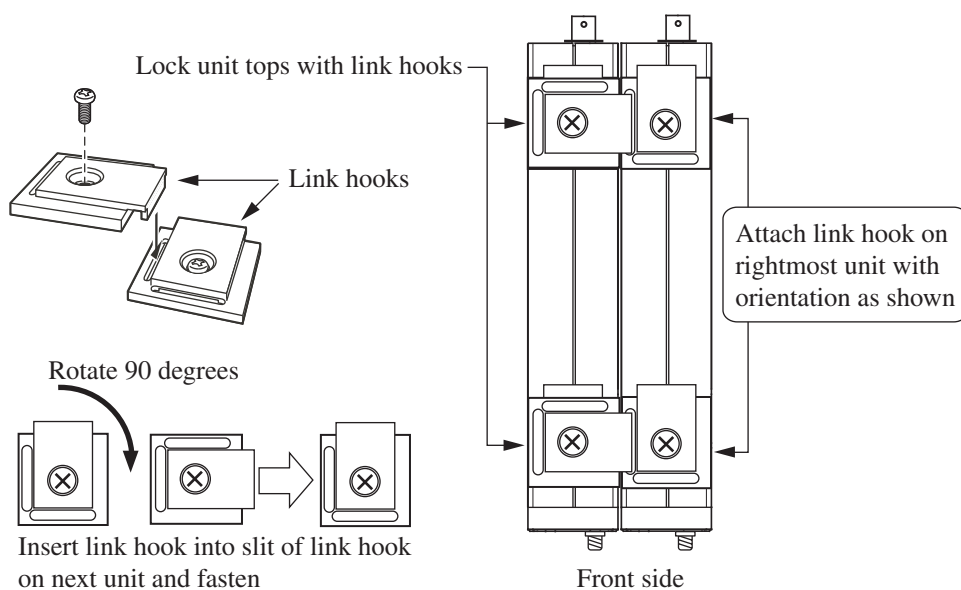

6. Attach the link hooks to the unit tops, so that the units are locked together.

Securely tighten all screws.

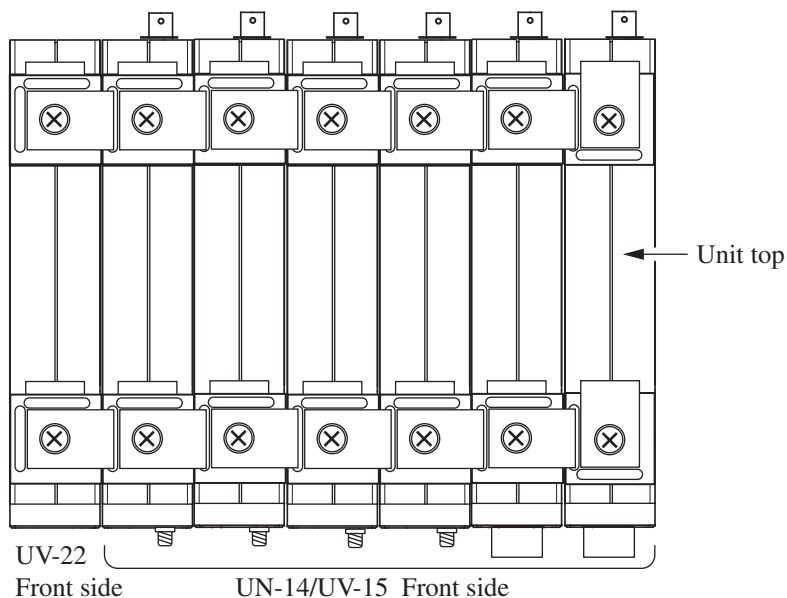

Note

If you have lost the original screws, refer to the information about maintenance parts on page 65. Commercially available screws can also be used, provided that exact specifications are met.

Fastening screw for link hook on unit top

Truss-head screw M4×8 (screw length 8 mm)

Fastening screw for link plate on unit bottom

Flat-head screw M3×10 (screw length 10 mm)

Screw types listed according to JIS B 1111.

Removing the cable from the link connector

To unplug the link connector, grasp the tag as shown in the illustration below and carefully pull the connector out.

Important

Be sure to grasp the side with the “3M” lettering. If you pull on the other side, the tag may break.

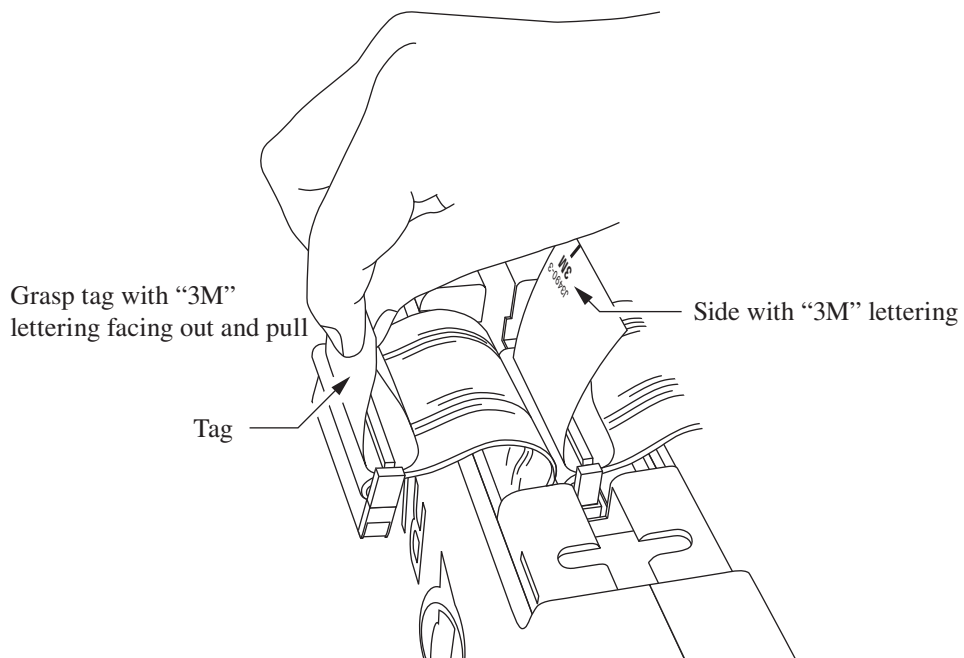

Power Supply Connection

The Interface Unit UV-22 has a power switch that can control power to the entire system.

To provide power, purchase the optional AC adapter NC-99 series.

Important

Connect the power only after assembling and linking the system.

Do not use any AC adapter other than the specified model. Otherwise malfunction and damage may occur.

Power supply limitations		
Power supply type	Max. number of units	
AC adapter (option)	NC-99 series	Up to 16 units
Battery Unit BP-17 (option)	IEC R14 (size C) battery×8	Up to 3 units

Connect the AC adapter to the Interface Unit UV-22.

If the Battery Unit BP-17 is part of the system, connect the AC adapter to the BP-17.

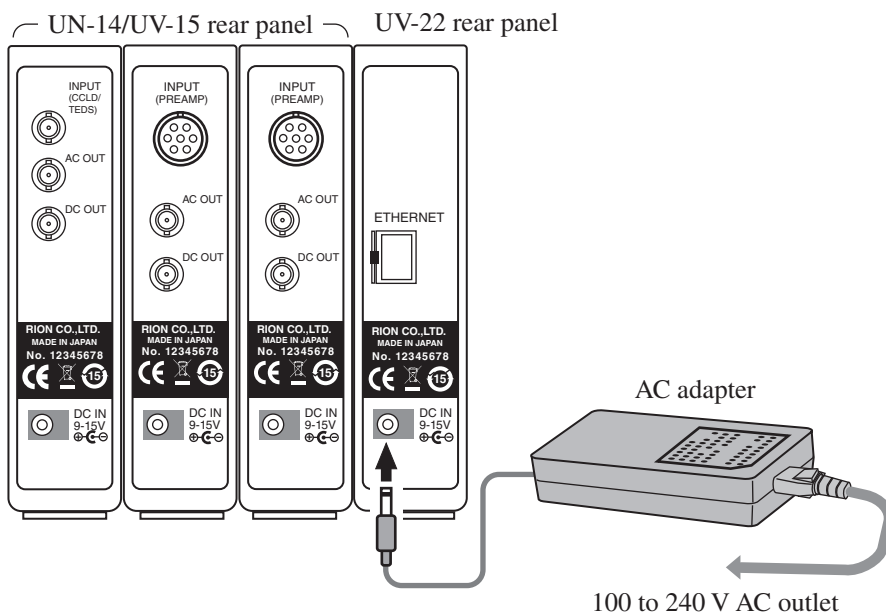

Preparations

Setting the ID number

When multiple UN-14 or UV-15 units are linked, you must assign a unique ID number to each unit for identification.

The setting is made with the operation keys on the UN-14 and UV-15. The default ID number setting both for the UN-14 and UV-15 is No.1. Be sure to change the setting when there is more than one unit. The setting range is No. 1 to No. 16.

The ID number is used to identify the unit for communication. If there is more than one unit in the same system with the same ID number, correct communication will not be possible.

See illustration below.

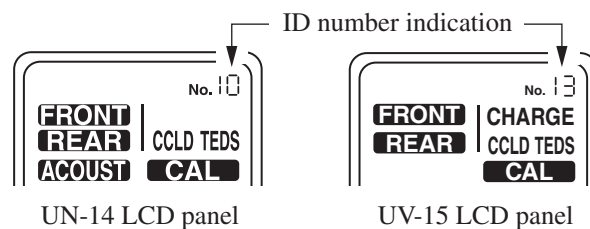

1. When you press the INPUT key on the operation panel of the UN-14 or UV-15 two or three times in succession, the ID number starts to flash.
2. Use the RANGE keys to set the number. When the setting is complete, press the MEAS key to return to the measurement screen.

Make the setting for each unit individually, so that each unit has a unique ID number.

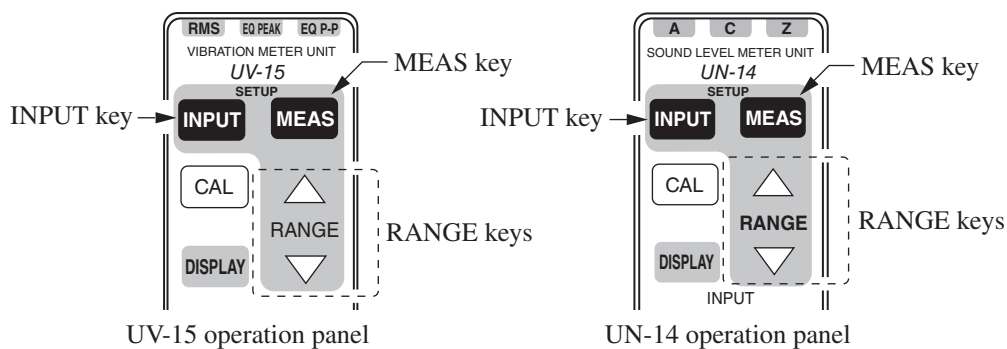

LOCAL (MASTER/SLAVE)

When the USB or Ethernet (LAN) interface is not to be used and measurement is controlled with the operation keys on each individual unit, or when wanting to use the Master/Slave function, set the communication function selector to “LOCAL (MASTER/SLAVE)”.

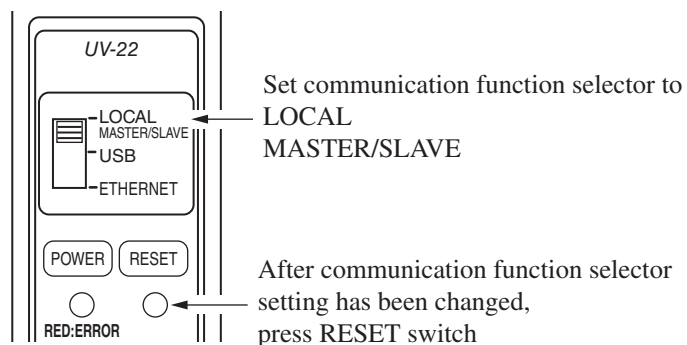

Items controlled by Master/Slave function

	UN-14	UV-15
CAL key	CAL ON/OFF	CAL ON/OFF
DISPLAY key	Numeric indication selection Instantaneous value/range display	Numeric indication selection Instantaneous value/range display
Setting selected with MEAS key	A, C, Z F, S, 10 ms HPF (except user filter) LPF (except user filter)	m/s ² , mm/s, mm RMS, EQ PEAK, EQ P-P HPF (except user filter) LPF (except user filter)

Master/Slave Operation

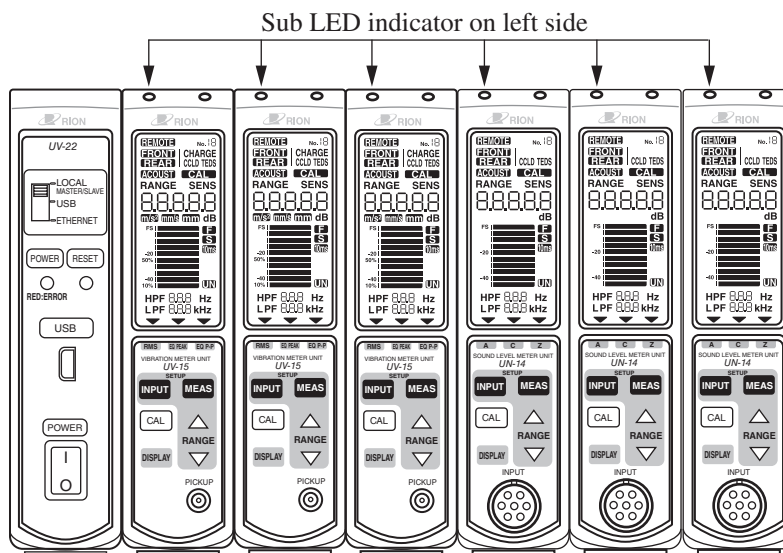

Master/Slave operation for calibration

Switching calibration on or off at one unit can be used to control calibration on/off for all other linked units as well.

Example: Use CAL key of one UV-15 unit

1. Select one of several linked UV-15 units. This unit is referred to as the Master unit, and all other UV-15 units will be Slave units.
2. While the Master unit is in the measurement mode, press and hold its CAL key for at least 2 seconds.

The sub LED indicator of the Master unit starts to flash in green.

Subsequently, the sub LED indicators of all linked UV-15 units (Slave units) briefly light up in green, and all units are switched to calibration mode. (If there are UN-14 units in the system, these will also be switched to calibration mode.)

3. To turn the calibration mode at all units off, repeat the procedure from step 1.

Master/Slave operation for setup

Settings made at one unit (Master unit) can be reflected at all other connected units of the same type. This function distinguishes between UN-14 and UV-15 units.

Example: Setup mode of UV-15

1. Select one of several linked UV-15 units. This unit is referred to as the Master unit, and all other UV-15 units will be Slave units.
2. While the Master unit is in the measurement mode, press and hold its MEAS key for at least 2 seconds.

The sub LED indicator of the Master unit starts to flash in green. Subsequently, the sub LED indicators of all linked UV-15 units (Slave units) briefly light up in green, and all units are switched to the same settings as selected on the Master unit.

Master/Slave operation for numeric readout switching

The numeric display setting made at one unit (Master unit) can be reflected at all other connected units (Slave units).

Example: Numeric readout of UV-15

1. Select one of several linked UV-15 units. This unit is referred to as the Master unit, and all other UV-15 units will be Slave units.
2. While the Master unit is in the measurement mode or calibration mode, press and hold its DISPLAY key for at least 2 seconds.

The sub LED indicator of the Master unit starts to flash in green. Subsequently, the sub LED indicators of all linked UV-15 units (Slave units) briefly light up in green, and all units are switched to the readout setting as selected on the Master unit (range indication or instantaneous value indication).

Note
The Master/Slave function distinguishes between UV-15 and UN-14.

Communication

The UV-22 supports two formats for communication with a computer: USB or Ethernet.

After establishing a connection, setup of the UN-14 and UV-15 units, measurement data readout, and user filter settings can be controlled from the computer.

Important

Also while connected via USB or Ethernet, the operation keys on the UV-15 or UN-14 can be used.

USB connection

When the USB interface is used, the computer must be connected as the host and the UV-22 as a device.

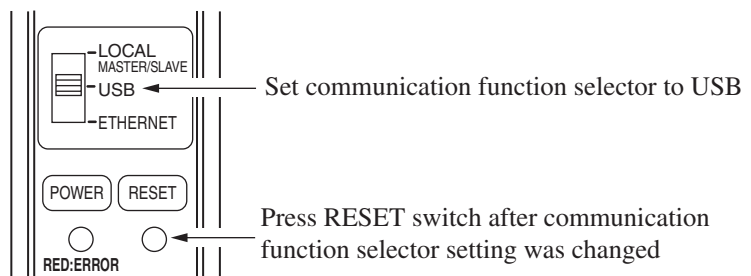
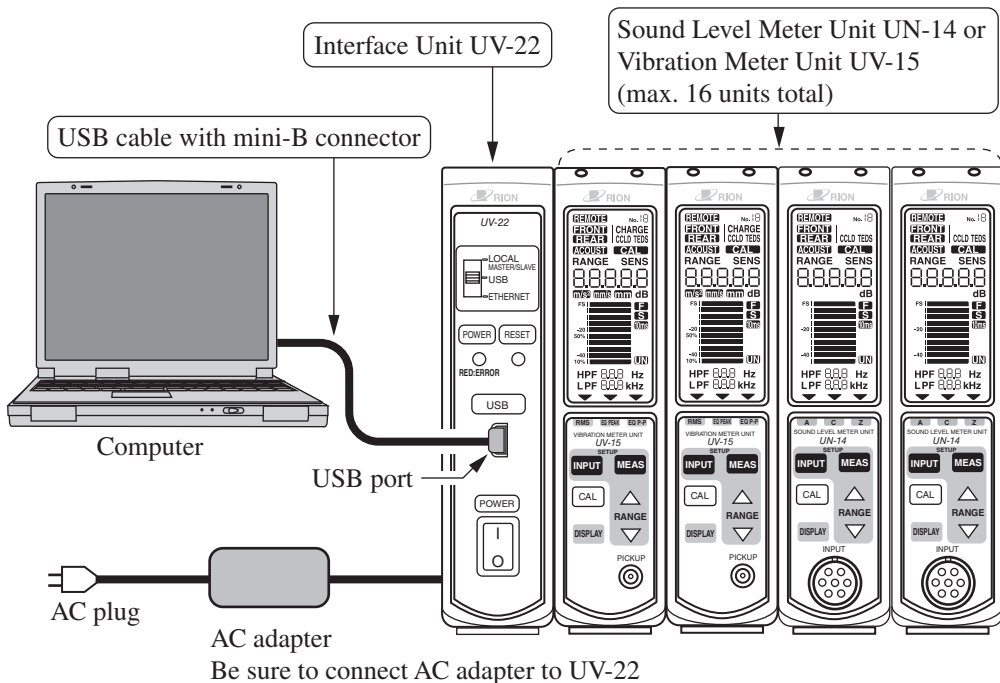

LAN connection

When the Ethernet (LAN) interface is used, the computer must be connected as a client and the UV-22 as a server.

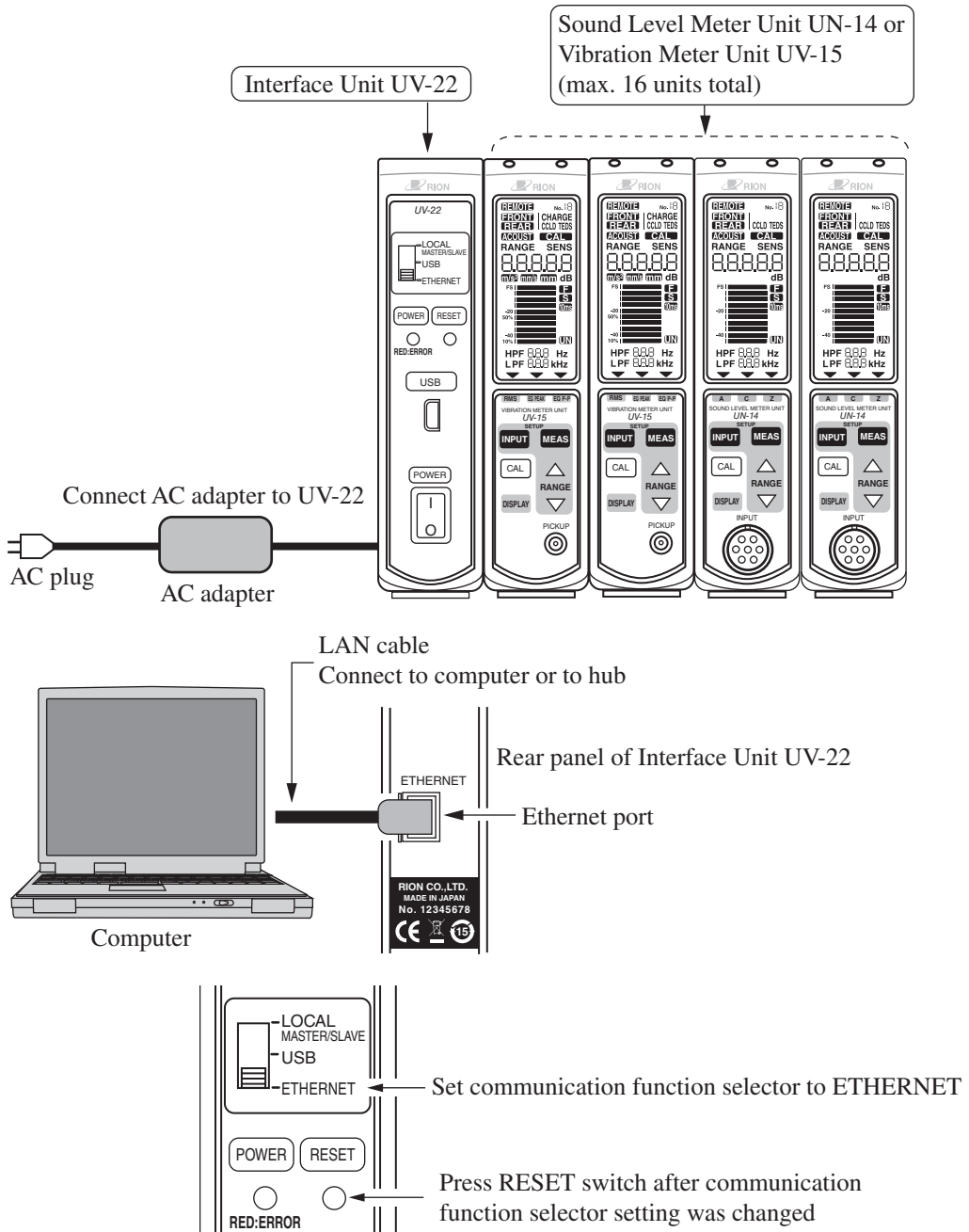

Installing the USB driver

To use USB for communication, the supplied USB driver must first be installed on the computer that you intend to use.

The USB driver is found on the CD-ROM supplied with the unit.

CD-ROM folder structure

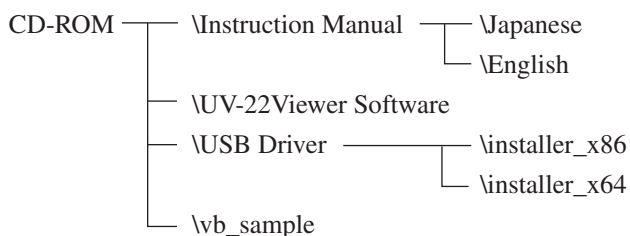

Instruction Manual folder

Contains the documentation in electronic format.

UV-22Viewer Software folder

Contains the UV-22Viewer application software.

USB Driver folder

Contains the USB driver.

installer_x86:

For 32 bit Microsoft Windows 8.1 Pro/10 Pro

installer_x64:

For 64 bit Microsoft Windows 8.1 Pro/10 Pro

vb_sample folder

Contains sample software for retrieving data from the UV-22 using the DOD command. The software is written in Visual Basic.

Installation procedure

1. Start up the computer. Close any other software that is running.

When using 32 bit OS, execute the file “setup.exe” located in the “installer_x86” folder.

When using 64 bit OS, execute the file “setup.exe” located in the “installer_x64” folder.

The installation starts.

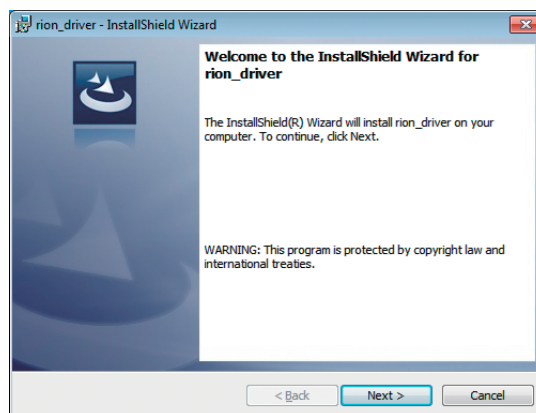

Follow the wizard to complete the installation.
Screens during installation are as follows.

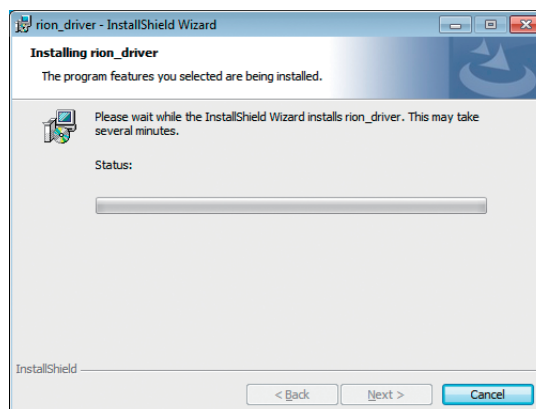
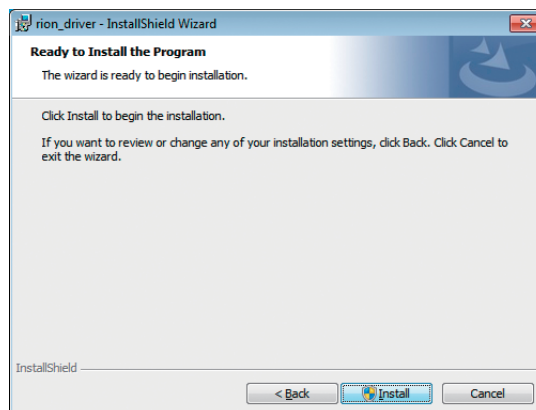
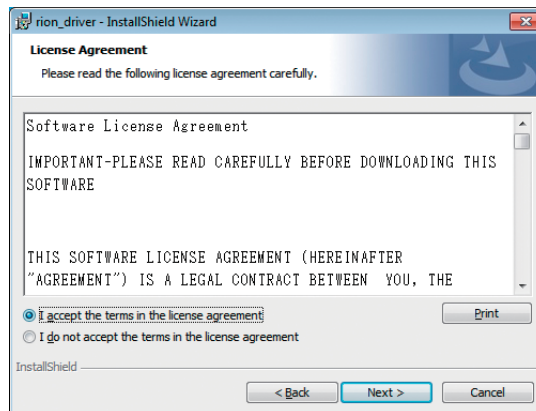

Depending on your environment, [Windows Security] may be displayed. Click on “Install” or “Continue”.

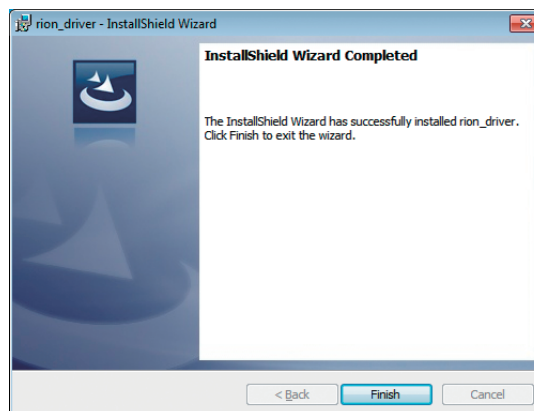
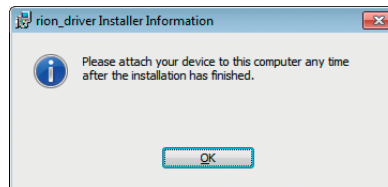
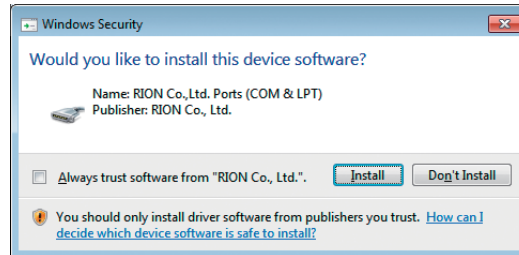

2. Make sure that the POWER switch of the UV-22 is set to OFF and that the communication function selector on the front panel is set to USB.
 3. Plug the USB cable into the USB port of the UV-22 and plug the other end of the cable into the USB port of the computer. Then turn on power to the UV-22.
- The USB driver can be installed also while the UV-22 is linked to UN-14 and UV-15 units.

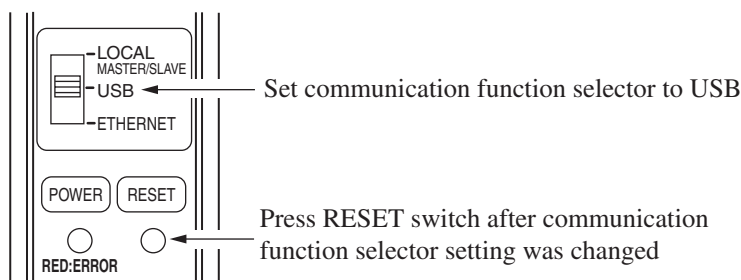
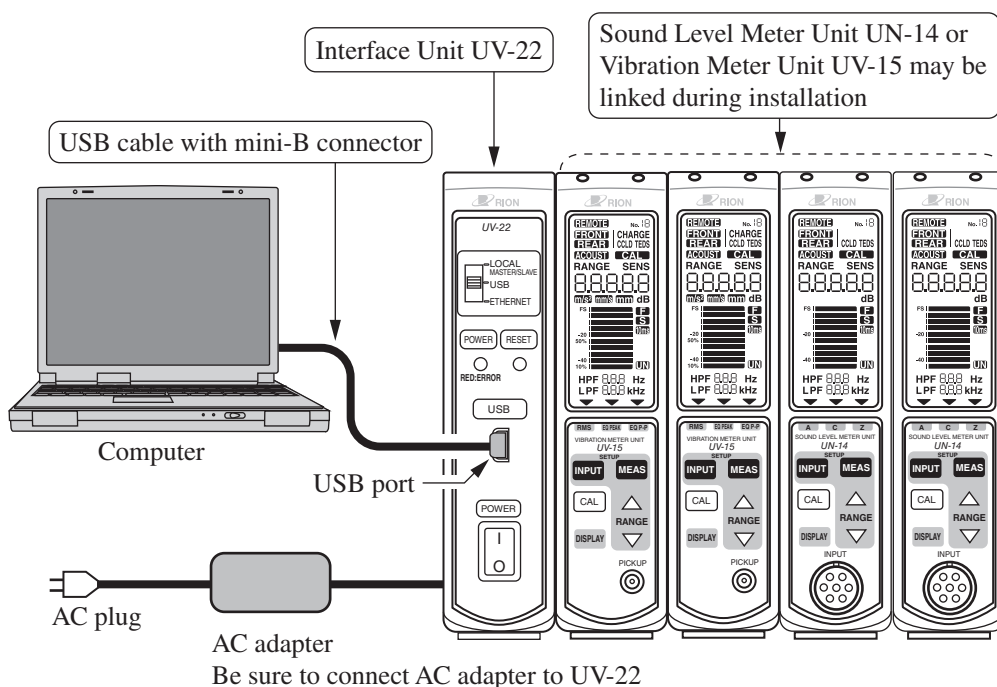

When the computer detects the UV-22, the device driver software installation is started automatically. When the installation has been completed, USB communication is enabled.

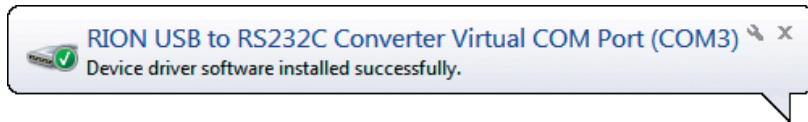

Ethernet setup

To use the Ethernet interface for connection to a computer, you must first make settings for IP address, subnet mask, and default gateway for the UV-22. To assign an IP address to the UV-22 and make other initial settings, the USB connection is used.

The UV-22Viewer software (on the supplied CD-ROM) has a function for easily making these settings.

Procedure

The following explanation assumes that the USB driver has been installed. Execute “UV-22Viewer.exe” to start the application. The initial screen such as shown below appears.

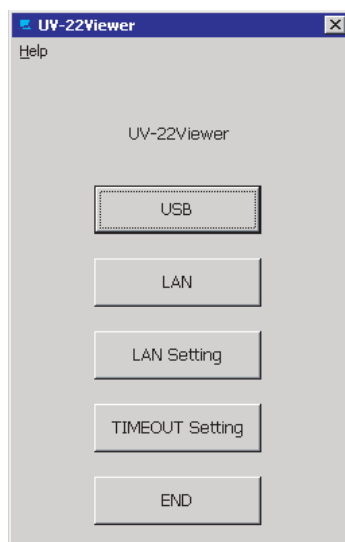

Initial screen

At the initial screen, click the “LAN Setting” button. The application connects to the UV-22 via the USB link.

When the connection has been established successfully, the LAN Setting screen appears.

Note
If a communication error has occurred, try restarting the computer and UV-22, or pressing the RESET switch on the UV-22.

The LAN Setting screen lets you use the computer to make LAN settings for the UV-22.

The LAN Setting screen gives access to the following items.

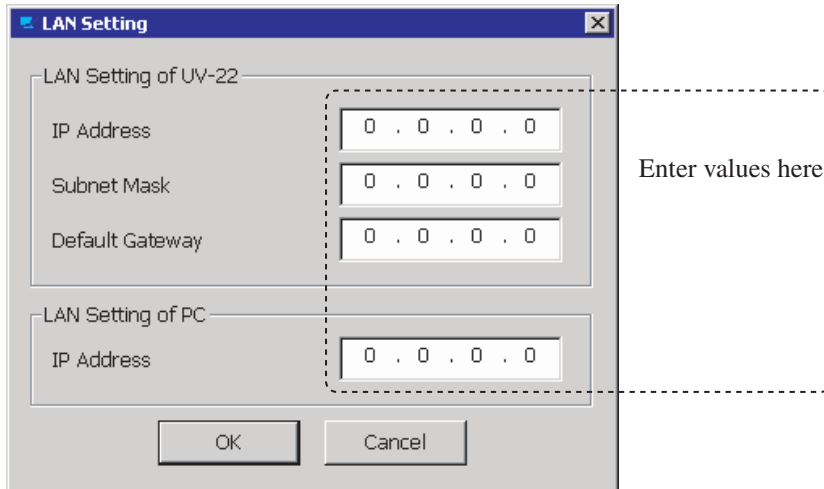

LAN Setting screen

(1) UV-22 LAN settings

This section comprises the following items. The settings are saved in the UV-22.

1) IP address

Specifies the IP address of the UV-22.

2) Subnet mask

Specifies the subnet mask of the UV-22.

3) Default gateway

Specifies the default gateway of the UV-22.

The factory default settings of the UV-22 are as shown below.

IP address:	192.168.100.100
Subnet mask:	255.255.255.0
Default gateway:	192.168.100.1

(2) PC LAN settings

This section comprises the following item. The setting is saved in the UV-22.

1) IP address

Specifies the IP address of the UV-22 connected to the computer via an Ethernet connection.

- * If there are multiple UV-22 units on the network, specify the IP address of the UV-22 with which you want to communicate. When using the UV-22 for which the settings in “UV-22 LAN settings” were made, the IP address setting will be the same.

When all items have been set, click on OK. This completes the LAN setup.

Important

When the unit is to be connected to a company network or similar, consult the network administrator regarding the appropriate settings for IP address, subnet mask, and default gateway.

Important

On a LAN, the actual communication speed (throughput) will depend on data traffic and communication conditions.

Important

The operation keys on the UN-14/UV-15 remain active also while using the UV-22Viewer software. If settings are changed with the keys while operation is controlled by software from the computer, a mismatch between the settings as managed by the software and the actual UN-14/UV-15 settings may occur.

Note

When communicating from software other than UV-22Viewer, specify TCP/IP port number: 2255.

Commands

Transfer method and sequence

Transfer codes

The codes used for communication with the UV-22 are as follows.

Control codes

Code	Hexadecimal notation	Meaning
<ENQ>	05H	Enquire
<ACK>	06H	Acknowledge
<NAK>	15H	Not Acknowledge
<STX>	02H	Start Block
<ETX>	03H	End Block
<CR>	0DH	Terminator, 1st character
<LF>	0AH	Terminator, 2nd character
<SUB>	1AH	Stop

Special codes

ATTR	Control code or character code	Block attribute
ID	01H to FFH	Remote Device/Local Device ID number
BCC	00H to FFH	Block Check Code

Command, parameter, data

ASCII code 20H to 7FH

Transfer format

Command block: Command from computer to UV-22

<STX>	ID	ATTR	Command	parameter	<ETX>	BCC	<CR>	<LF>
1	1	1	M	N	1	1	1	1 byte

ATTR = 'C'

When there are multiple parameters, a space is used as delimiter.

Data response block: Response from UV-22. Response data are ASCII.

<STX>	ID	ATTR	Data response	<ETX>	BCC	<CR>	<LF>
1	1	1	N	1	1	1	1 byte

ATTR = 'A' or 'Q'

When there are multiple parameters, a comma “,” is used as delimiter.

Acknowledge response block: Computer or UV-22

<STX>	ID	ATTR	<ETX>	BCC	<CR>	<LF>
1	1	1	1	1	1	1 byte

ATTR = <ACK>

Not Acknowledge response block: Computer or UV-22

<STX>	ID	ATTR	Error code	<ETX>	BCC	<CR>	<LF>
1	1	1	4	1	1	1	1 byte

ATTR = <NAK>

Enquire block: From computer to UV-22

<STX>	ID	ATTR	<ETX>	BCC	<CR>	<LF>
1	1	1	1	1	1	1 byte

ATTR = <ENQ>

Stop request block: From computer to UV-22

<STX>	ID	ATTR	<ETX>	BCC	<CR>	<LF>
1	1	1	1	1	1	1 byte

ATTR = <SUB>

Stop request code: From computer to UV-22

<SUB>

1 byte

This section explains the functions of “ID”, “ATTR”, and “BCC” in the transfer format block.

ID: ID Number

The ID number is 1 (01H) in binary notation.

ATTR: Block Attribute

The block attribute information is added by the sender, to facilitate processing of the block at the receiving end.

Code	Hexadecimal notation	Meaning
<ACK>	06H	Acknowledge block
<NAK>	15H	Not Acknowledge block
<ENQ>	05H	Enquire block
<SUB>	1AH	Stop request block
<EOT>	03H	End of transmission block
‘C’	43H	Command block
‘A’	41H	Data response block (last block)
‘Q’	51H	Data response block (midstream block)

BCC: Block Check Code

The BCC information is added by the sender. At the receiving end, the following range is calculated for verification.

Calculation range: From ID to ETX

Calculation method: 8 bit part of exclusive logic sum for calculation range

If a block sent from the computer contains 00H (NULL) as BCC, block check is skipped at the measuring unit. This allows simplified transmission from the computer.

Block reception processing

For reception processing, the unit is initially in the <STX> wait (idling) mode, except during a sequence while waiting for response from the computer.

In idling mode, the Interface Unit UV-22 disregards any data except <STX>.

Command types

There are two types of commands: setting commands and request commands.

Setting command

This type of command serves for setting or changing the various parameters of the unit. Some commands will produce a response from the unit, while others are executed without response.

For commands that have a response, this is returned after the setting command has been processed.

Request command

This type of command serves for getting information about unit settings and for obtaining measurement data including display data. The unit returns the requested data.

Error processing

Transmission errors

Transmission errors can be detected in the following categories.

Error item	Content	Processing
Block reset	<STX> received after incomplete block (excluding ID number)	Start block again from that point

Command processing errors

Block format is correct, but command interpretation or processing has resulted in an error.

Error item	Content	Processing
Undefined command	Command problem	Return error code 0001
Parameter error	Parameter number or value is not correct	Return error code 0002
Processing error	Processing cannot be carried out in current state	Return error code 0003
Processing timeout	Timeout interval has elapsed	Return error code 0004

Transfer sequence

The following transfer types exist.

- Check device sequence
- Setting sequence
- Request sequence
- Continuous request sequence
- Error response

The setting sequence can be selected to have a response or not.

Check device sequence

An acknowledge block is returned in response to the check device block.

This is a standalone sequence which requires no preparation.

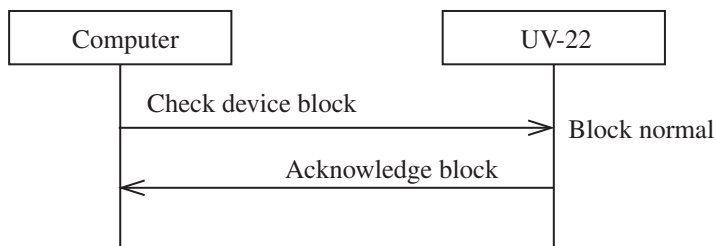

Setting sequence

Normal execution

After command processing, an Acknowledge response is sent.

“After command processing” refers to the point where processing has commenced, not where processing is completed.

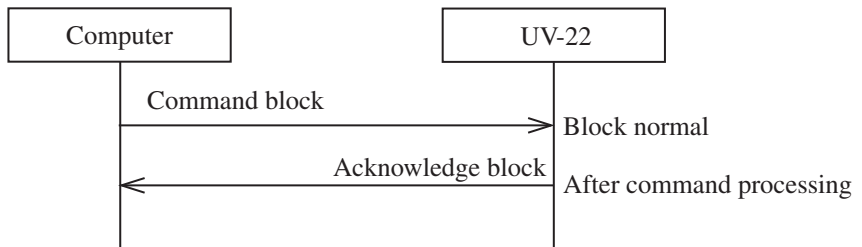

Abnormal execution

When a block or command processing error has occurred, a Not Acknowledge response is sent.

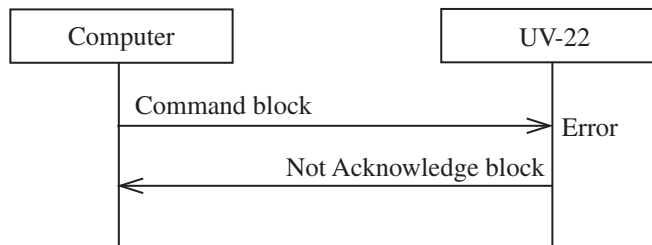

Request sequence (1 block)

Normal execution

The response is sent immediately after receiving the request command.

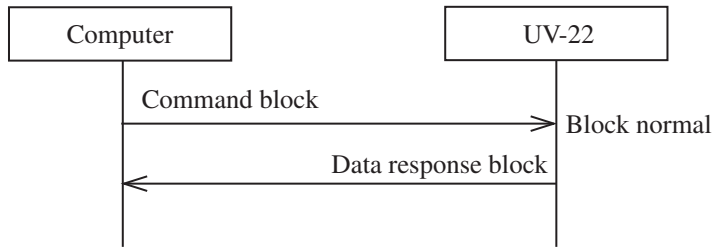

Abnormal execution

When a block or command processing error has occurred, a Not Acknowledge response is sent.

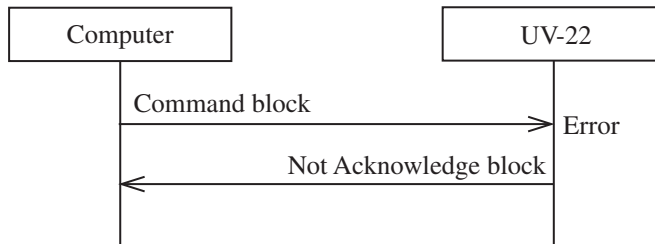

Request sequence (multiple blocks)

Normal execution

In principle, there is no need for a response to be sent from the computer, and blocks are sent continuously from the UV-22.

To stop the transmission, the computer sends a stop request code. Any other command is disregarded by the UV-22.

When sending a stop request code to UV-22, wait until the current block has been fully sent. (Do not send a stop request code in the middle of a block.)

After the last block has been sent, the UV-22 goes into the idling state.

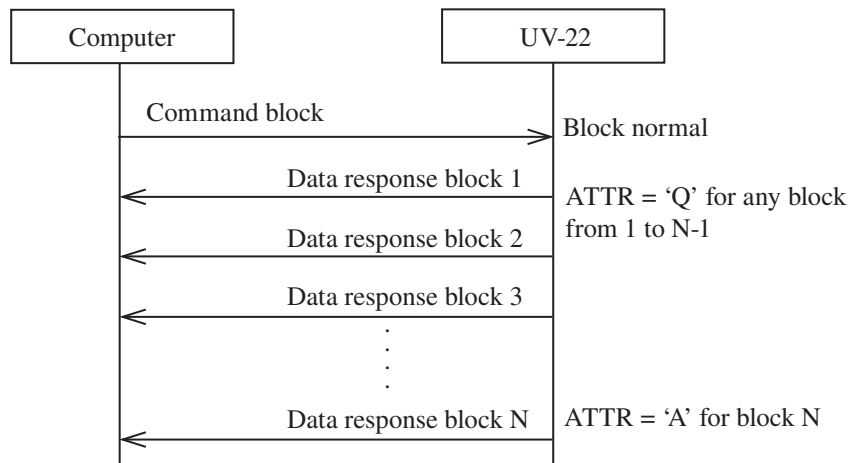

Continuous request sequence

This sequence is used only for the command to periodically request measurement data (DRD command).

Normal execution

In principle, there is no need for a response to be sent from the computer, and blocks are sent periodically from the UV-22.

To stop the transmission, the computer sends a stop request code. Any other command is disregarded by the UV-22.

Before the transmission stops completely, several data response blocks may be sent from the UV-22. Therefore an Acknowledge response is sent when the transmission is completed.

After the transmission has stopped, the UV-22 goes into the idling state.

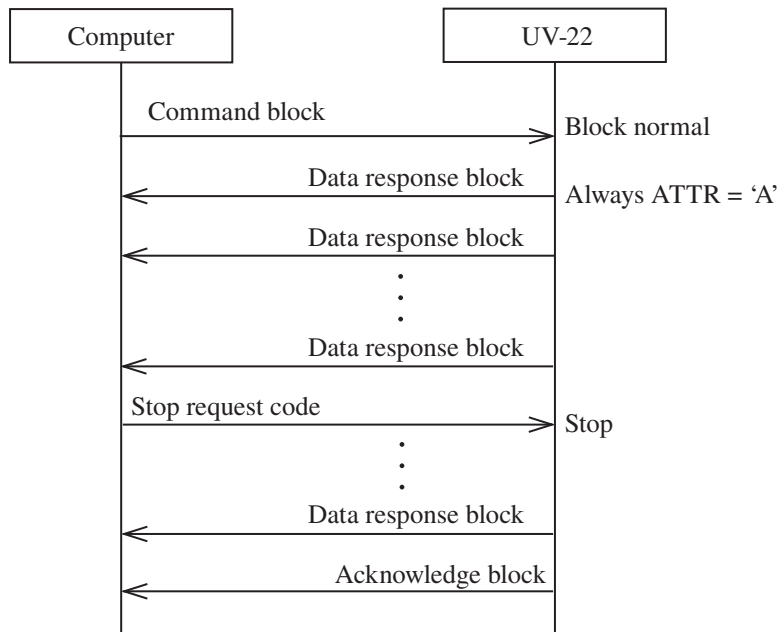

Error response

When an error generating a response on the block level has occurred, the following sequence occurs.

After the error response, the unit returns to the idling state and does not continue to send multiple blocks or carry out other communication tasks.

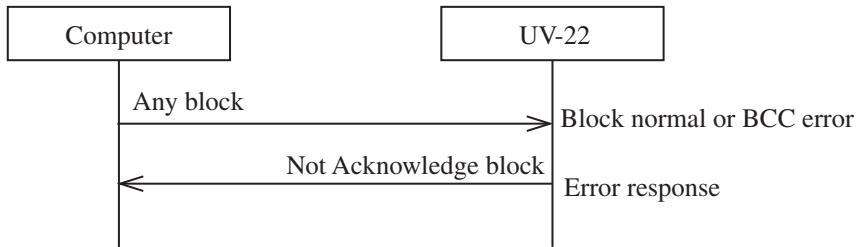

Ratings

Guaranteed values

Case	Rating	Remarks
UV-22 response time	Max. 3 sec	“Processing timeout” error response in case of processing problem
Send character interval	Max. 100 msec	————
Interval until UV-22 enters idling state after sending data	Max. 200 msec	————

* Depending LAN connection condition, network configuration, and network traffic, slight delays may occur.

Rated values

Case	Rating	Remarks
ACK wait after multiple block request sequence	10 sec	Cancel sequence and return to idling state
Flow control send timeout	3 sec	Cancel sequence and return to idling state
Block generation wait time after receiving <STX>	No limit	————
Receive character interval timeout	No limit	————

Commands

Command	Function	See page
DID	Get ID number of UN-14/UV-15	44
CAL	Set/Get calibration on/off status	44
DPY	Set/Get instantaneous value display/range display ...	45
INP	Set/Get input settings	45
MSS	Set/Get measurement settings.....	47
SNS	Set/Get sensitivity setting.....	48
RNG	Set/Get range setting	49
TDS	Get TEDS communication status	50
TSI	Get TEDS sensor information	50
TEC	Cancel TEDS error status.....	51
UHF	Set user filter HPF value.....	51
ULF	Set user filter LPF value	52
DOD	Get current measurement value	53
DRD	Get continuous measurement value	53
IPA	Set/Get IP address.....	53
DCL	Restore factory default settings	55
VER	Get version information.....	55

Command Format

In this manual, a single character is represented as “□”, a space as “_”, parameters as “p1,p2,...”, and response data as “d1,d2,...”. Parameters and response data may be more than 1 character long.

Commands consists of three letters which are not case-sensitive (upper-case or lower-case can be used).

□□□

When a command has a parameter, the parameter follows the command. It can be appended to the command either directly or with a separating space.

□□□p1 Valid

□□□_p1 Valid

When a command has several parameters, the parameters must be separated by a space.

□□□p1_p2 Valid

□□□p1p2 Not valid

Note
One command block can only contain one command. Do not include several commands in a block.

A request command consists of the command, any required parameter, and a “?”. The command and “?” or parameter and “?” may be separated by a space.

□□□? Valid

□□□_? Valid

□ p1? Valid

□□□p1_? Valid

Unless specified otherwise, parameters and response data are of variable

length. Depending on the value range, the length of the parameter will differ. Measures such as padding with leading zeros are not implemented.

□□□_1	Valid
□□□_10	Valid
□□□_01	Not valid

Command Reference

DID (Device InDex)

Get: ID number setting of device

Request command	DID?
Response data	d1,d2,d3,d4,d5,...,d17
d1	0: No ID number duplication 1: ID number duplication
d2	Device with ID number 1 0: None 14: UN-14 15: UV-15
d3	Device with ID number 2
d4	Device with ID number 3
d5	Device with ID number 4
	:
	:
d17	Device with ID number 16

Transfer format: response block

CAL (CALibration)

Set: Calibration mode on/off

Setting command	CAL p1 p2
p1	Target device ID number (1 to 16, 244 [all UN-14 units], 245 [all UV-15 units])
p2	CAL On/Off (0: OFF, 1: ON)

Transfer format: response block

Get: Calibration mode on/off status

Request command	CAL? p1
	p1 Target device ID number (1 to 16)
Response data	d1
d1	CAL On/Off

Transfer format: response block

DPY (DisPlaY)

Set: Instantaneous value display/range display

Setting command DPY p1 p2
 p1 Target device ID number
 (1 to 16, 244 [all UN-14 units], 245 [all UV-15
 units])
 p2 Select instantaneous value display/range
 display
 (0: instantaneous value display 1: range
 display)

Transfer format: response block

Get: Instantaneous value display/range display ON/OFF

Request command DPY? p1
 p1 Target device ID number (1 to 16)

Response data d1
 d1 Instantaneous value display/range display
 Transfer format: response block

INP (INPut)

Set: Input settings

Setting command INP p1 p2 p3 p4 p5
 p1 Target device ID number (1 to 16)
 p2 Front/Rear
 0: Front 1: Rear
 p3 Charge On/Off
 0: Charge Off 1: Charge On
 p4 CCLD On/Off
 0: CCLD Off 1: CCLD On
 p5 TEDS On/Off
 0: TEDS Off 1: TEDS On

Transfer format: response block

Setting values for p2 to p5

	Input settings	p2	p3	p4	p5
UN-14	Front (7-pin connector)	0	0	0	0
	Rear (BNC connector)	1	0	1	0
	Rear CCLD TEDS (BNC connector) (TEDS compliant sensor)	1	0	1	1
UV-15	Front Charge (Microdot connector) (Piezoelectric accelerometer)	0	1	0	0
	Front CCLD (Microdot connector) (Accelerometer with built-in preamplifier)	0	0	1	0
	Front CCLD TEDS (Microdot connector) (TEDS compliant sensor)	0	0	1	1
	Rear (7-pin connector) (VP-26A connected)	1	0	0	0

Get: Input settings

INP? p1

p1 Target device ID number (1 to 16)

Response data

d1,d2,d3,d4

d1 Front/Rear

d2 Charge On/Off

d3 CCLD On/Off

d4 TEDS On/Off

Transfer format: response block

MSS (MeaSure Setting)

Set: Measurement settings

Setting command	MSS p1 p2 p3 p4 p5
p1	Target device ID number (1 to 16, 244 [all UN-14 units], 245 [all UV-15 units])
p2	For UN-14: Select time weighting characteristics (1: Fast 2: Slow 3: 10 ms) For UV-15: Select measurement mode (1: Acceleration 2: Velocity 3: Displacement)
p3	For UN-14: Select frequency weighting characteristics (1: A weighting 2: C weighting 3: Z weighting) For UV-15: Select indication characteristics (1: RMS 2: EQ PEAK 3: EQ P-P)
p4	For UN-14: Select HPF (1: OFF 2: 20 Hz 3: User filter) For UV-15: Select HPF (1: OFF 2: 3 Hz 3: 5 Hz 4: 10 Hz 5: 15 Hz 6: 20 Hz 7: 30 Hz 8: 50 Hz 9: 100 Hz 10: 150 Hz 11: 200 Hz 12: User filter)
p5	For UN-14: Select LPF (1: OFF 2: 20 Hz 3: User filter) For UV-15: Select LPF (1: OFF 2: 300 Hz 3: 500 Hz 4: 1 kHz 5: 1.5 kHz 6: 2 kHz 7: 3 kHz 8: 5 kHz 9: 10 kHz 10: 15 kHz 11: 20 kHz 12: User filter)
	Transfer format: response block

Response data d1,d2
 d1 Sensitivity value
 d2 Decimal point position
 Transfer format: response block

RNG (RaNGe)

Set: Range setting

Setting command RNG p1 p2
 p1 Target device ID number (1 to 16)
 p2 Range
 Transfer format: response block

For UN-14: 0 to 5 (For setting values, see table below)

Sensitivity	Setting value					
	0	1	2	3	4	5
-10.0 to -19.9	70	80	90	100	110	120
-20.0 to -29.9	80	90	100	110	120	130
-30.0 to -39.9	90	100	110	120	130	140
-40.0 to -49.9	100	110	120	130	140	150
-50.0 to -59.9	110	120	130	140	150	160

For UV-15: 0 to 6 (For setting values, see table below)

Sensitivity	Measurement mode	Setting value						
		0	1	2	3	4	5	6
0.100 to 0.999	Acceleration	10	30	100	300	1000	3000	10000
	Velocity	10	30	100	300	1000	3000	10000
	Displacement	1	3	10	30	100	300	1000
1.00 to 9.99	Acceleration	1	3	10	30	100	300	1000
	Velocity	1	3	10	30	100	300	1000
	Displacement	0.1	0.3	1	3	10	30	100
10.0 to 99.9	Acceleration	0.1	0.3	1	3	10	30	100
	Velocity	0.1	0.3	1	3	10	30	100
	Displacement	0.01	0.03	0.1	0.3	1	3	10

Get: Range setting

Request command RNG? p1
 p1 Target device ID number (1 to 16)
 Response data d1
 d1 Range
 Transfer format: response block

TDS (TeDS)

Get: TEDS communication status

When TEDS communication was enabled with the INP command, the communication result can be obtained with this command.

Request command	TDS? p1
	p1 Target device ID number (1 to 16)
Response data	d1
	d1 TEDS communication status
	0: TEDS communication not enabled
	1: TEDS communication in progress (result of input setting TEDS ON)
	2: TEDS communication completed normally (sensitivity value obtained)
	3: TEDS communication failed
	Transfer format: response block

TSI (Teds Sensor Info)

Get: TEDS sensor information

Request command	TSI? p1
	p1 Target device ID number (1 to 16)
	Transfer format: response block
Response data	d1,d2,d3
	d1 ROM No.
	ROM No. information (8 bytes equivalent) binary code expressed as a hex string (16 characters)
	d2 BASIC TEDS
	BASIC TEDS information (8 bytes equivalent) binary code expressed as a hex string (16 characters)

d3 Template information
 Template information (16 bytes equivalent)
 binary code expressed as a hex string (32
 characters)
 (Template information is obtained up to
 16 bytes)
 Transfer format: response block

TEC (Teds Error Clear)

Set: Cancel TEDS error indication from TEDS query by UN-14/UV-15

Setting command TEC p1
 p1 Target device ID number (1 to 16)
 Transfer format: response block

UHF (User High pass Filter)

Set: User filter HPF value

Setting command UHF p1 p2
 p1 Target device ID number (1 to 16)
 p2 User HPF cutoff frequency
 0: 3 Hz, 1: 3.15 Hz, 2: 4 Hz, 3: 5 Hz,
 4: 6.3 Hz, 5: 8 Hz, 6: 10 Hz, 7: 12.5 Hz,
 8: 15 Hz, 9: 16 Hz, 10: 20 Hz, 11: 25 Hz,
 12: 30 Hz, 13: 31.5 Hz, 14: 40 Hz, 15: 50 Hz,
 16: 63 Hz, 17: 80 Hz, 18: 100 Hz, 19: 125 Hz,
 20: 150 Hz, 21: 160 Hz
 -1: OFF,
 Transfer format: response block

Get: User filter HPF value

Request command UHF? p1
 p1 Target device ID number (1 to 16)
 Response data d1
 d1 User HPF cutoff frequency
 Transfer format: response block

ULF (User Low pass Filter)

Set: User filter LPF value

Setting command ULF p1 p2
p1 Target device ID number (1 to 16)
p2 User HPF cutoff frequency
UN-14
0: 300 Hz, 1: 315 Hz, 2: 400 Hz, 3: 500 Hz,
4: 630 Hz, 5: 800 Hz, 6: 1 kHz, 7: 1.25 kHz,
8: 1.5 kHz, 9: 1.6 kHz, 10: 2 kHz, 11: 2.5 kHz,
12: 3 kHz, 13: 3.15 kHz, 14: 4 kHz, 15: 5 kHz,
16: 6.3 kHz, 17: 8 kHz, 18: 10 kHz,
19: 12.5 kHz, 20: 15 kHz, 21: 16 kHz,
22: 20 kHz, 23: 25 kHz, 24: 31.5 kHz,
25: 40 kHz, 26: 50 kHz
-1: OFF,
UV-15
0: 300 Hz, 1: 315 Hz, 2: 400 Hz, 3: 500 Hz,
4: 630 Hz, 5: 800 Hz, 6: 1 kHz, 7: 1.25 kHz,
8: 1.5 kHz, 9: 1.6 kHz, 10: 2 kHz, 11: 2.5 kHz,
12: 3 kHz, 13: 3.15 kHz, 14: 4 kHz, 15: 5 kHz,
16: 6.3 kHz, 17: 8 kHz, 18: 10 kHz,
19: 12.5 kHz, 20: 15 kHz, 21: 16 kHz,
22: 20 kHz
-1: OFF
Transfer format: response block

Get: User filter LPF value

Request command ULF? p1
p1 Target device ID number (1 to 16)
Response data d1
d1 User LPF cutoff frequency
Transfer format: response block

DOD

Get: Current measurement value

Request command DOD?

Response data

For details on response data, see “Getting measurement values” on page 56.

DRD

Get: Continuous measurement value

Request command DRD?

Response data

For details on response data, see “Getting measurement values” on page 56.

To stop continuous measurement values, send <SUB>.

IPA (IP Address)

Set: IP address

Setting command	IPA p1 p2 p3 p4 to p12
	p1 1st byte of IP address
	p2 2nd byte of IP address
	p3 3rd byte of IP address
	p4 4th byte of IP address
	p5 1st byte of subnet mask
	p6 2nd byte of subnet mask
	p7 3rd byte of subnet mask
	p8 4th byte of subnet mask
	p9 1st byte of default gateway
	p10 2nd byte of default gateway
	p11 3rd byte of default gateway
	p12 4th byte of default gateway
	Transfer format: response block

Get: IP address

Request command	IPA?
Response data	d1,d2,d3,d4 to d12
	d1 1st byte of IP address
	d2 2nd byte of IP address
	d3 3rd byte of IP address
	d4 4th byte of IP address
	d5 1st byte of subnet mask
	d6 2nd byte of subnet mask
	d7 3rd byte of subnet mask
	d8 4th byte of subnet mask
	d9 1st byte of default gateway
	d10 2nd byte of default gateway
	d11 3rd byte of default gateway
	d12 4th byte of default gateway
	Transfer format: response block

If this command is used while connected via LAN, communication may become unstable. Use this command only while connected via USB.

DCL (Data CLear)

Set: Restore factory default settings

Setting command DCL

VER (VERsion)

Get: Version information

Request command VER?

Response data d1

d1 CPU firmware version of UV-22

Transfer format: response block

Getting measurement values

Start continuous measurement value transmission

Sending the DRD command starts continuous transmission of measurement values.

In this condition, the UV-22 automatically sends measurement value data every 100 ms.

Stop continuous measurement value transmission

To stop the transmission, send the single-byte command <SUB> (0x1A). Take the <ACK> packet as response.

If the UV-22 receives the command while continuous measurement value transmission is not in progress, the command is disregarded.

Measurement value get/stop sequence

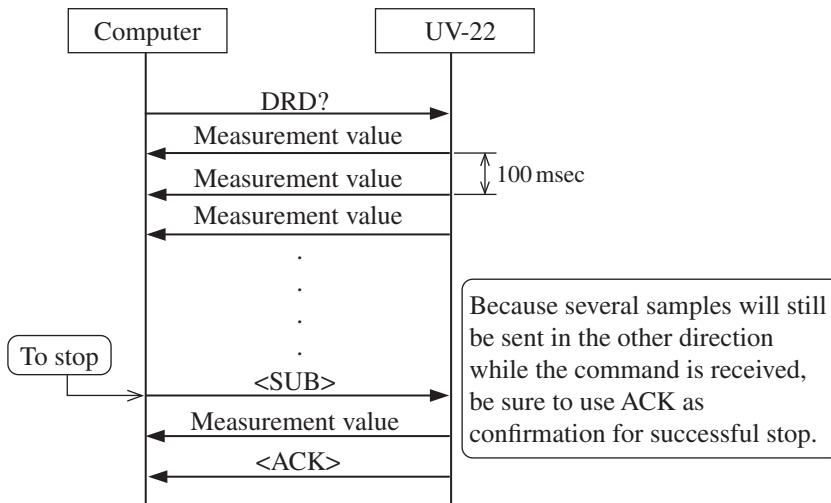

Measurement value data format

Measurement data are sent using the following format.

d1,d2,d3,d4,....,d15,d16

- d1 Measurement data of device with ID number 1
- d2 Measurement data of device with ID number 2
- d3 Measurement data of device with ID number 3
- d4 Measurement data of device with ID number 4
- :
- :
- d15 Measurement data of device with ID number 15
- d16 Measurement data of device with ID number 16

The measurement data for each device (d1 to d11) use the following internal configuration.

d1,d2,d3,d4,d5,d6,d7,d8,d9,d10,d11

- d1 Display value
- d2 Instantaneous value every 100 ms
- d3 Maximum value
- d4 UN-14 Peak
UV-15 +Peak
- d5 UN-14 $L_{eq}100$ ms
UV-15 -Peak
- d6 Over
0: No
1: Yes
- d7 Under
0: No (Normally, 0 is returned)
1: Yes

- d8 Reserved
Numeric value is invalid.
- d9 Range (for numeric values, see table in RNG command section)
- d10 UN-14 0 (fixed)
UV-15 Measurement mode (for numeric values, see MSS command section)
- d11 Lap counter (0 to 9)
Incremented by every 100 ms when data are sent.
Identical counter value indicates that data are identical.
If counter value jumps by 2 or more compared to previous value, data are being dropped.

Note
Because transmission sampling and measurement sampling of UV-22 and specified UN-14/UV-15 units are separate, identical data or data drop may occur on rare occasions.

All data for ID numbers of devices that do not exist are 0 (zero).

Example for getting measurement value data from UV-15

Target device:	1
Input signal:	Front
Measurement mode:	Acceleration
Indication characteristics:	RMS
HPF:	None
LPF:	None
Sensitivity:	5.00
Range:	100

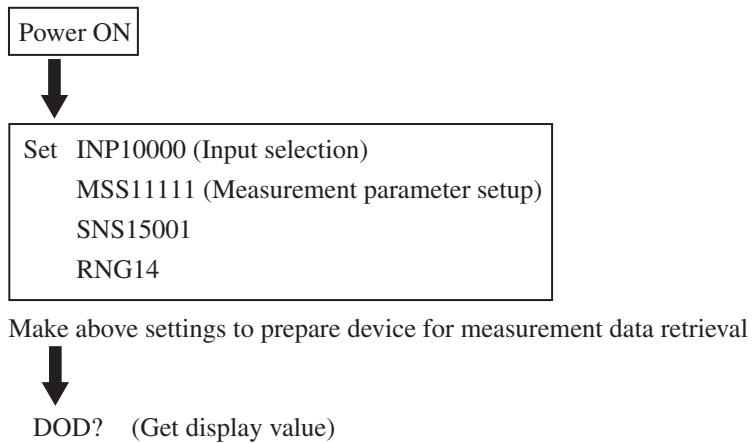

Supplied CD-ROM

CD-ROM folder structure

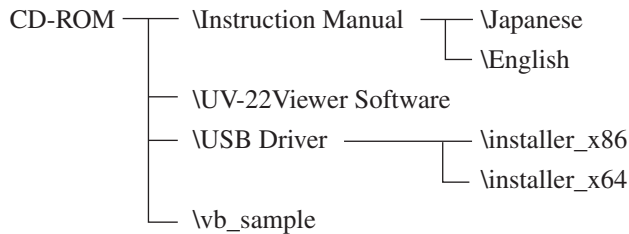

Instruction Manual folder

Contains the documentation in electronic format.

UV-22Viewer Software folder

Contains the UV-22Viewer application software.

USB Driver folder

Contains the USB driver.

installer_x86:

For 32 bit Microsoft Windows 8.1 Pro/10 Pro

installer_x64:

For 64 bit Microsoft Windows 8.1 Pro/10 Pro

vb_sample folder

Contains sample software for retrieving data from the UV-22 using the DOD command. The software is written in Visual Basic.

Specifications

Applicable standards CE marking, UKCA marking, China RoHS

UN-14/UV-15 Interface

Number of connected units: up to a combined total of sixteen UN-14/UV-15 units

Interfaces

USB USB 1.1
(one UV-22 per computer supported)
Connector: Mini B

Ethernet 10/100 Base-TX
(one UV-22 per computer supported)

TCP/IP port number
2255

Temperature/humidity range for operation

-10°C to +50°C, max. 90% RH

Temperature/humidity range for storage

-10°C to +50°C, max. 90% RH

Power supply

9 V to 15 V DC

Suitable AC adapter:

NC-99 series (up to sixteen UN-14/UV-15 units and one UV-22 unit)

Battery Unit:

BP-17

Automotive 12 V battery:

CC-82 (Car battery adapter)

Current consumption:

approx. 240 mA (12 V DC, Ethernet or USB operation)

Dimensions and weight

150 mm (H) × 36 mm (W) × 179 mm (D)

Approx. 500 g

Supplied accessories

CD-ROM (Instruction Manual for UV-22, UV-22Viewer software, Instruction Manual for UV-22Viewer software, USB driver, and sample software)

1

USB cable (USB Mini-B, 5-pin) KU-AMB518

1

Concise Manual

1

M3 flat-head screw 3×10

2

Inspection certificate

1

Optional accessories

AC adapter

NC-99 series

(up to sixteen UN-14/UV-15 units and one UV-22 unit)

Battery Unit

BP-17

Rack Mounting Base

CF-27

Sound Level Meter Unit

UN-14

Vibration Meter Unit

UV-15

Car battery adapter

CC-82

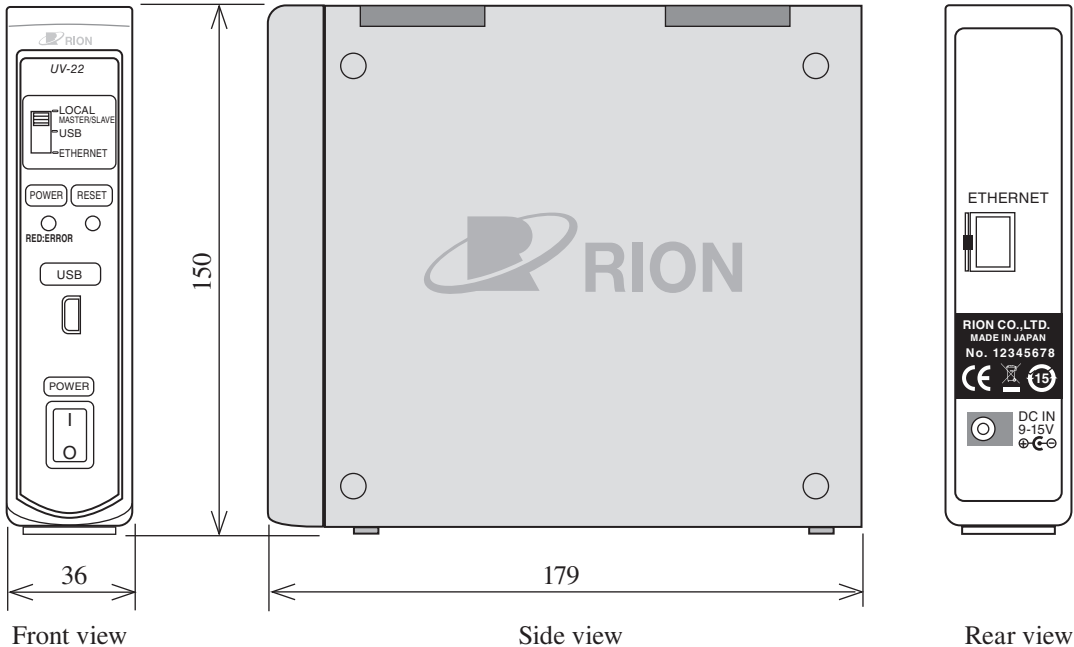

Unit: mm

Dimensional Drawing

Rack Mounting Base

The dimensional drawing of the optional accessory, rack mounting base CF-27 is shown below.

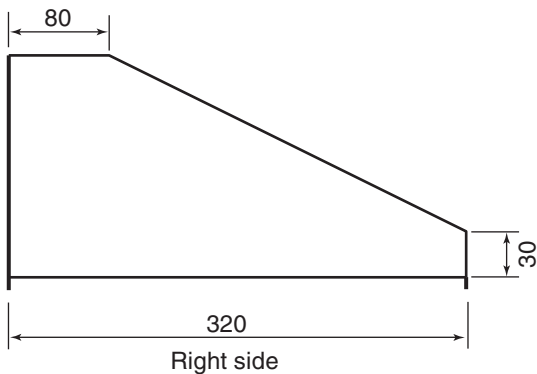
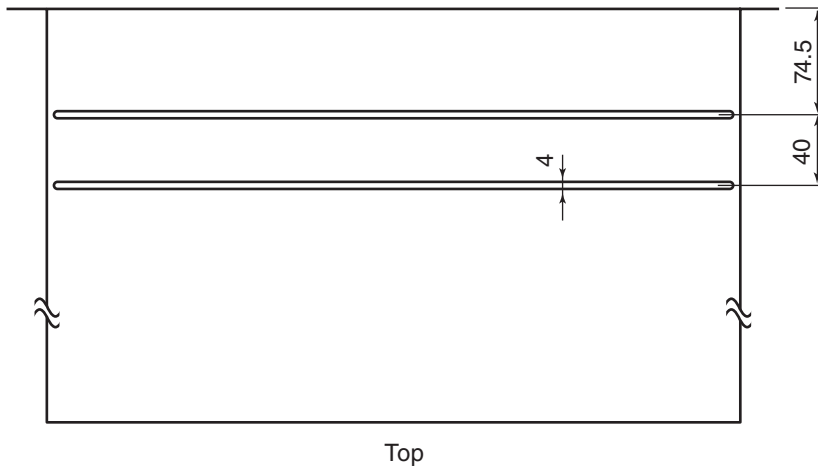
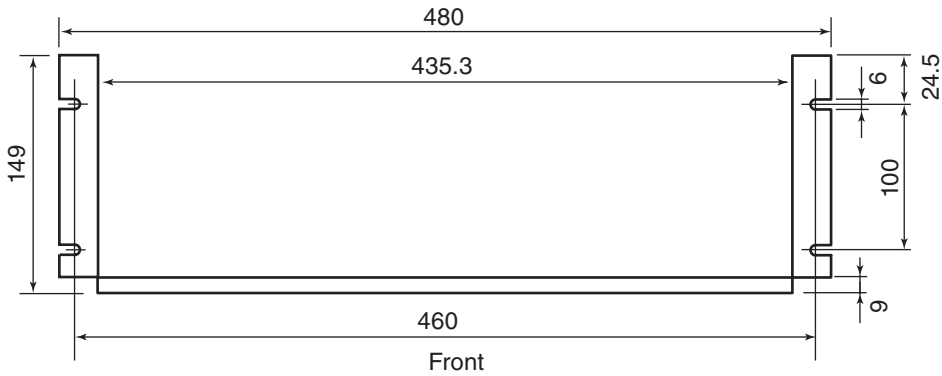

Board thickness: 1.6

Material: SPCC (cold rolled sheets)
with rust prevention treatment

Painting color: Munsell N 7.5

Unit: mm

Reference Material

Maintenance parts

If parts such as link hook, cover plate, or screws were lost by mistake, contact the supplier to obtain replacements.

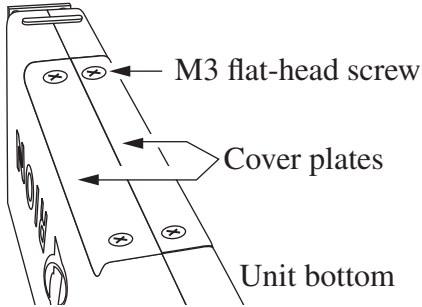

Part name: Cover plate
Part number: UV-16-008
Part name: M3 flat-head screw
Rion designation: KS 3 × 10
Conventional market designation:
Flat-head screw M3 × 10
Screw length 10 mm

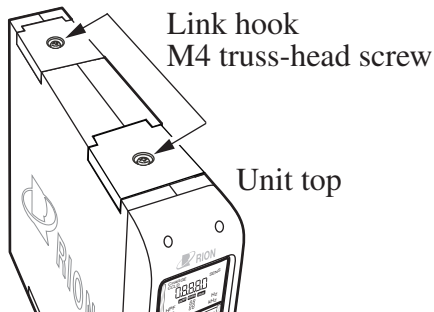

Part name: Link hook
Part number: UV-16-004
Part name: M4 truss-head screw
Rion designation: KT 4 × 8
Conventional market designation:
truss-head screw M4 × 8
Screw length 8 mm

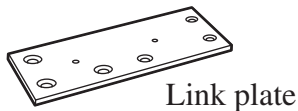

Part name: Link plate
Part number: UV-16-007

User Filter

UV-15 user filter frequency characteristics are shown below.

UV-15 HPF frequency characteristics

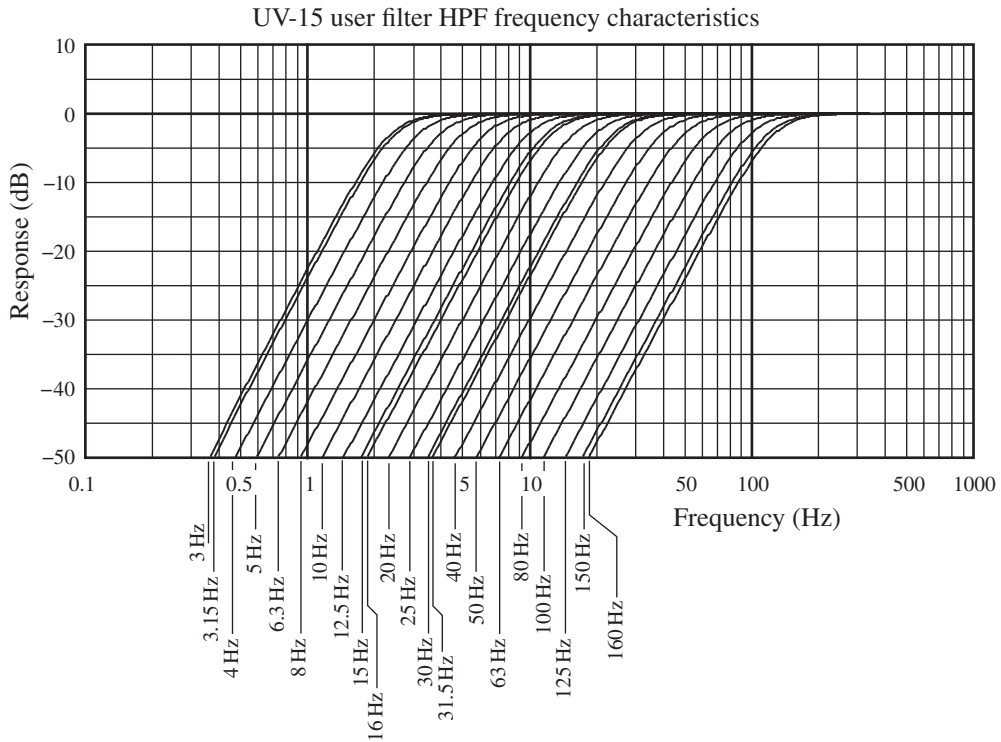

HPF (High-pass filter cutoff frequency: -10% attenuation)

3 Hz, 3.15 Hz, 4 Hz, 5 Hz, 6.3 Hz, 8 Hz, 10 Hz, 12.5 Hz, 15 Hz,
16 Hz, 20 Hz, 25 Hz, 30 Hz, 31.5 Hz, 40 Hz, 50 Hz, 63 Hz, 80 Hz,
100 Hz, 125 Hz, 150 Hz, 160 Hz

Attenuation slope: -18 dB/oct

UV-15 LPF frequency characteristics

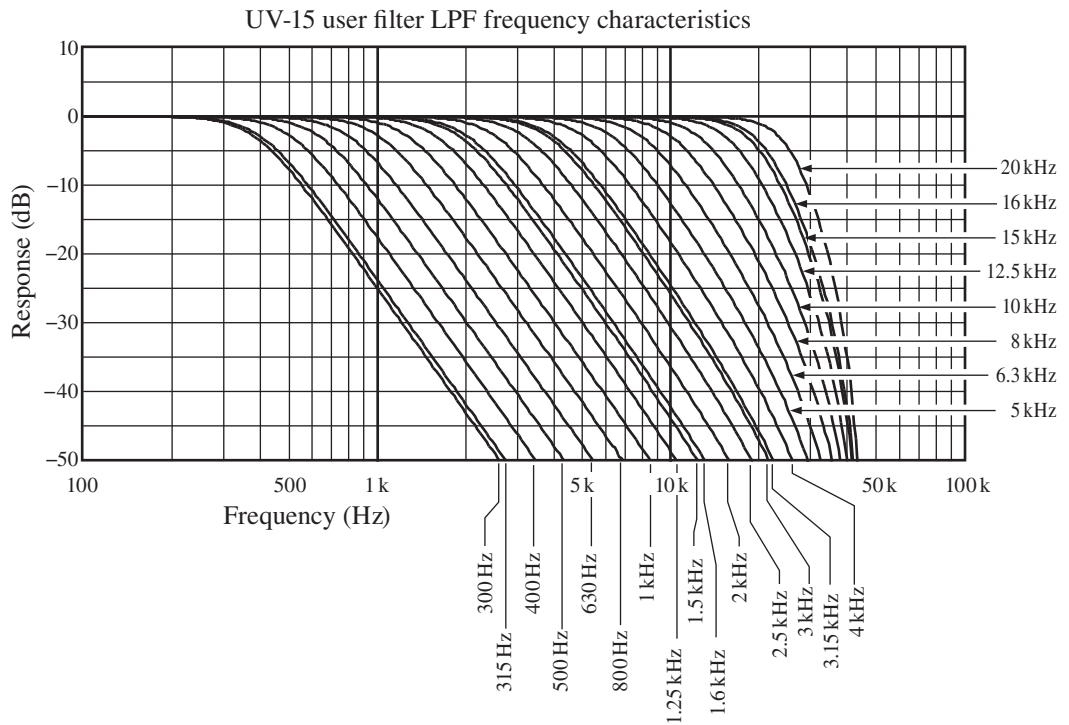

LPF (Low-pass filter cutoff frequency: -10% attenuation)

300 Hz, 315 Hz, 400 Hz, 500 Hz, 630 Hz, 800 Hz, 1 kHz, 1.25 kHz,
1.5 kHz, 1.6 kHz, 2 kHz, 2.5 kHz, 3 kHz, 3.15 kHz, 4 kHz, 5 kHz,
6.3 kHz, 8 kHz, 10 kHz, 12.5 kHz, 15 kHz, 16 kHz, 20 kHz

Attenuation slope: -18 dB/oct

UN-14 user filter frequency characteristics are shown below.

UN-14 HPF frequency characteristics

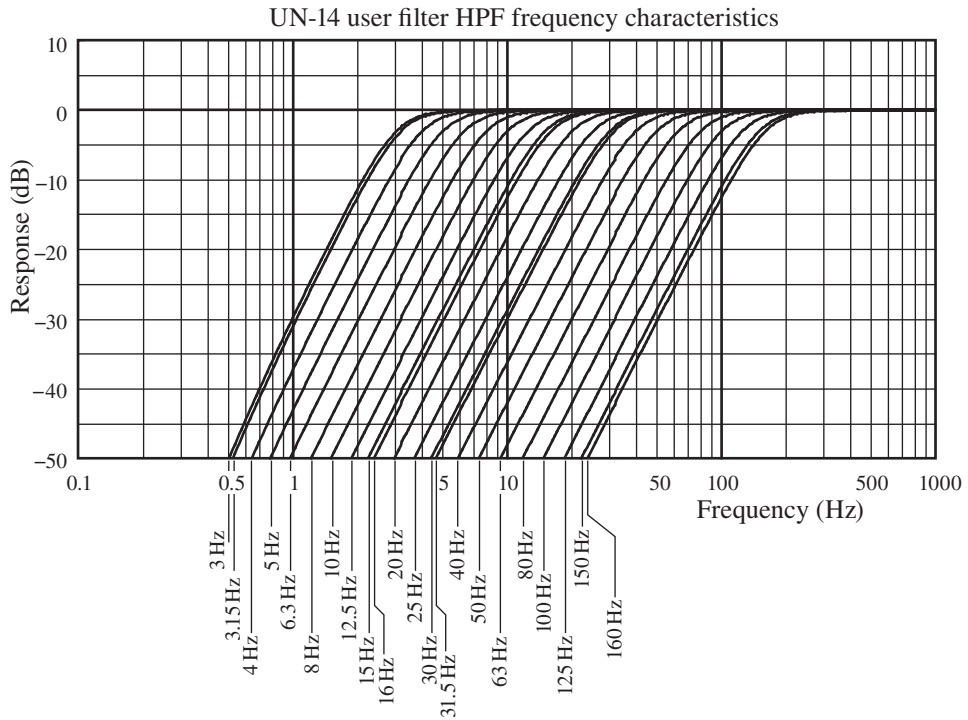

HPF (High-pass filter cutoff frequency: -3 dB attenuation)

3 Hz, 3.15 Hz, 4 Hz, 5 Hz, 6.3 Hz, 8 Hz, 10 Hz, 12.5 Hz, 15 Hz,
16 Hz, 20 Hz, 25 Hz, 30 Hz, 31.5 Hz, 40 Hz, 50 Hz, 63 Hz, 80 Hz,
100 Hz, 125 Hz, 150 Hz, 160 Hz

Attenuation slope: -18 dB/oct

UN-14 LPF frequency characteristics

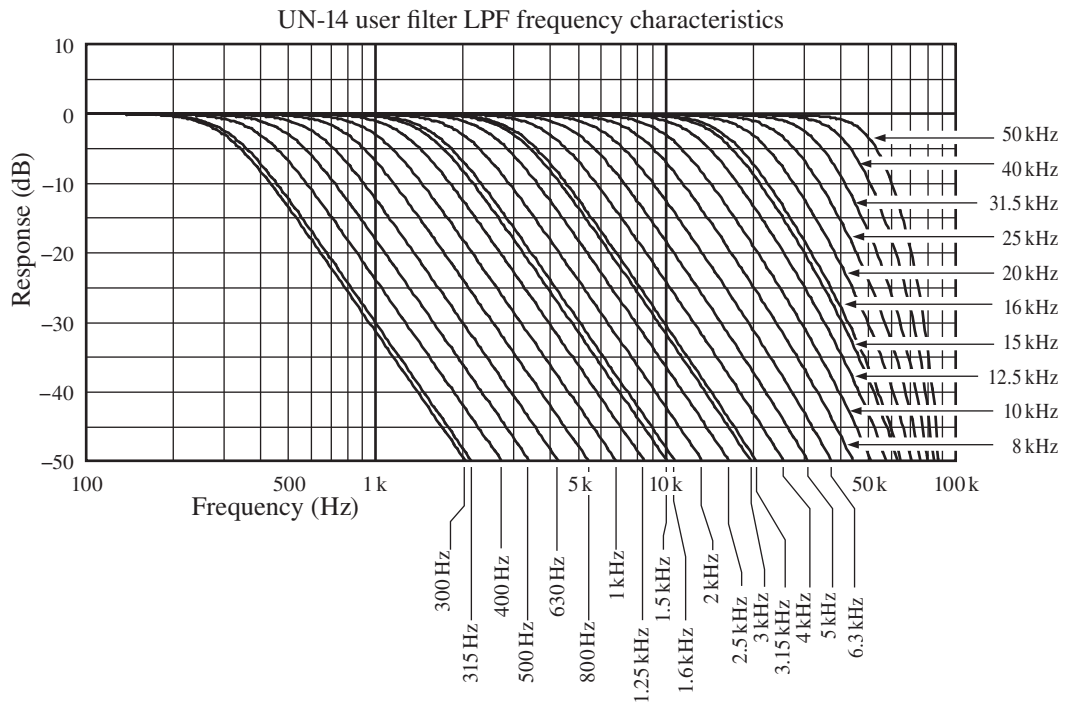

LPF (Low-pass filter cutoff frequency: -3 dB attenuation)

300 Hz, 315 Hz, 400 Hz, 500 Hz, 630 Hz, 800 Hz, 1 kHz, 1.25 kHz, 1.5 kHz, 1.6 kHz, 2 kHz, 2.5 kHz, 3 kHz, 3.15 kHz, 4 kHz, 5 kHz, 6.3 kHz, 8 kHz, 10 kHz, 12.5 kHz, 15 kHz, 16 kHz, 20 kHz, 25 kHz, 31.5 kHz, 40 kHz, 50 kHz

Attenuation slope: -18 dB/oct

