

INSTRUCTION MANUAL

VISCOTESTER

VT-05 / VT-06



3-20-41 Higashimotomachi, Kokubunji, Tokyo 185-8533, Japan

<http://www.rion.co.jp/english/>

Organization of this manual

This manual describes the features and operation principles of the Viscotester VT-05 (for low viscosity measurement) and VT-06 (for high viscosity measurement). The following pages contain important information on safety. Be sure to read this part.

This manual contains the following sections.

Outline

Gives basic information on the features of the unit.

Controls and functions

Briefly identifies and explains all controls and other parts of the unit.

Preparations

Explains how to make power connections and how to mount the rotor and cup.

Measurement

Describes how to perform the measurement.

Applied part

Describes rotor extension for VT-06.

Specifications

Lists the technical specifications of the unit

- * All company names and product names mentioned in this manual are trademarks or registered trademarks of their respective owners.

FOR SAFETY

In this manual, important safety instructions are specially marked as shown below. To prevent the risk of injury to persons and severe damage to the unit or peripheral equipment, make sure that all instructions are fully understood and observed.

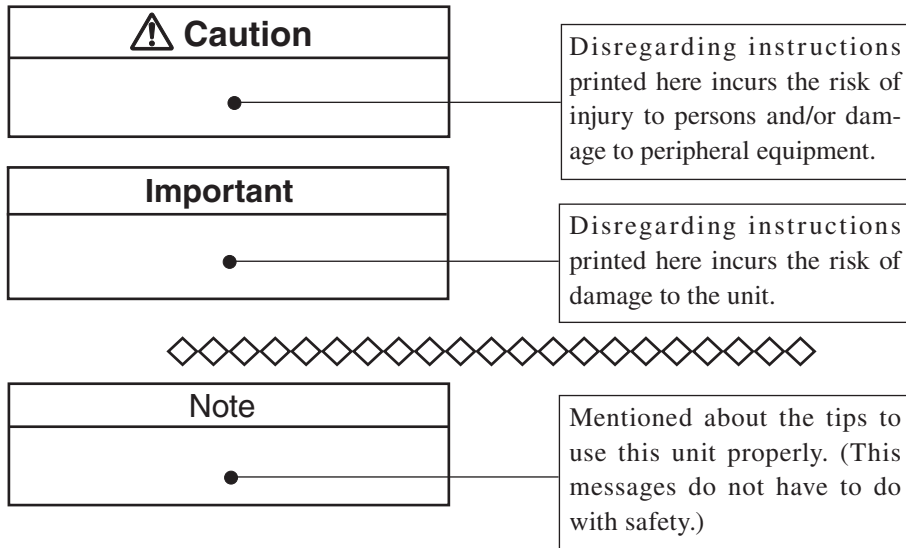

Precautions

VT-05

- The unit is designed for making measurements using cup A containing about 460 mL of sample fluid. If another container is used, the viscosity resistance working on the rotor will be different, leading to deviations in the measurement result.
- The viscosity scale readings for the various rotor types overlap in part. For example, the following viscosity ranges can be measured with the following both rotors:

15 to 33 mPa•s: No. 4 or No. 5 rotor

50 to 150 mPa•s: No. 5 or No. 3 rotor

However, depending on the properties of the sample fluid and on mechanical calibration results, the obtained measurement values may be different when changing rotors. To facilitate the correct evaluation of data, you should therefore note the rotor number along with the measurement results.

VT-06

- The No. 1 rotor and No. 2 rotor are designed for making measurements using a JIS 300 mL beaker containing about 350 mL of sample fluid. If another container is used, the viscosity resistance working on the rotor will be different, leading to deviations in the measurement result. If a different container has to be used, make sure that it is considerably larger than the JIS 300 mL beaker. In this case, the obtained measurement values will be low.

The No. 3 rotor must be combined with the No. 3 cup, otherwise large errors will occur in the reading.

*The actual capacity of the JIS 300 mL beaker is about 420 mL.

- The viscosity scale readings for the various rotor types overlap in part. For example, the following viscosity ranges can be measured with the following both rotors:

3 to 13 dPa•s: No. 3 or No. 1 rotor

100 to 150 dPa•s: No. 2 or No. 1 rotor

However, depending on the properties of the sample fluid and on mechanical calibration results, the obtained measurement values may be different when changing rotors. To facilitate the correct evaluation of data, you should therefore note the rotor number along with the measurement results.

Common precautions

- Keep the time for one measurement under 100 seconds.
- Ambient conditions for operation of the unit are as follows:
temperature range 5°C to 35°C, relative humidity 10% to 90%RH.
- Because the drive section is not hermetically sealed, do not use the unit in environments with volatile gas or dust pollution. Otherwise the drive section may be damaged.
- When attaching or removing a rotor, put the viscotester in a horizontal position and carefully move the rotor in the vertical direction. To prevent the possibility of damage, take care not to exert strong force on the rotor mounting shaft in the vertical or horizontal direction.
- The rotor mounting shaft is screwed into the body of the unit. Take care not to inadvertently dislodge it when attaching or removing a rotor.

- The rubber section of the rotor mounting shaft may drop out at the time of measurement. When you want to avoid the foreign material to a sample, remove the rubber section at the time of measurement.
- Remove the batteries from the unit when it is not being used, to prevent the possibility of damage by leaking battery fluid.
- Protect the unit from water, dust, extreme temperatures, humidity, and direct sunlight during storage. Also keep the unit away from air with high salt or sulphur content, gases, and stored chemicals during storage and use.
- Do not try to disassemble or alter the unit.
- Dispose of the unit and of batteries only according to national and local regulations at the place of use.
- Do not tap the LCD panel of the unit with a pointed object such as a pencil, screwdriver, etc.

- Clean the unit only by wiping it with a soft, dry cloth or, when necessary, with a cloth lightly moistened with water. Do not use any solvents, cleaning alcohol or chemical cleaning agents.
- The optional stand (VA-04) is useful to stabilize the viscotester during long-term or continuous measurements.
- To ensure continued accuracy, have the unit checked and serviced at regular intervals. Contact the supplier.
- In case of malfunction, do not attempt any repairs. Note the condition of the unit clearly and contact the supplier.

Change in viscosity unit

According to Japanese and international standard agreements, the viscosity unit is displayed in the Pascal-second (Pa•s). The relation between the Pa•s and Poise (P) is as follows.

- VT-05: 1 mPa•s = 1 cP
 mPa•s: Millipascal-seconds
 cP: Centipoise
- VT-06: 1 dPa•s = 1 P
 dPa•s: Decipascal-seconds
 P: Poise

Contents

FOR SAFETY.....	iii
Change in viscosity unit.....	x
Outline.....	1
Controls and functions.....	2
Configuration (VT-05).....	2
Configuration (VT-06).....	3
Top view.....	4
Rear view.....	5
Bottom view.....	6
Display.....	7
Operation key panel.....	8

Preparations	10
Power Supply	10
Attaching the Rotor and Cup (VT-05)	15
Attaching the Rotor (VT-06)	17
Preparing the Sample Fluid	18
Measurement.....	20
Applied part	24
Rotor extension (only for VT-06)	24
Specifications	25

Outline

The Viscotester VT-05/VT-06 is a compact, uni-cylinder rotational viscometer designed for easy use in the field. When a rotor put into the sample liquid is rotated by fixed speed, a viscous resistance is caused. Viscosity can be measured by detecting the viscous resistance (torque). Three different types of rotors are supplied, covering a wide range of applications.

Controls and functions

Configuration (VT-05)

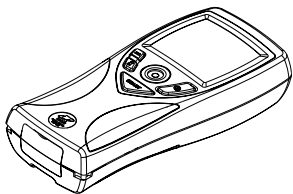

Main unit



No. 3 rotor

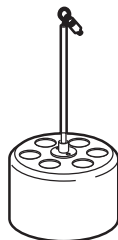

No. 4 rotor

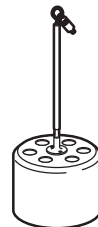

No. 5 rotor

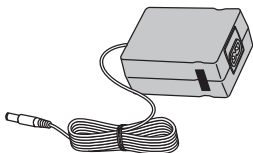

AC adapter (option)



IEC LR6
(size AA)
batteries

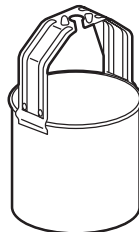

Cup A (no cutout)

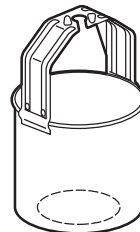

Cup B (with cutout)

Configuration (VT-06)

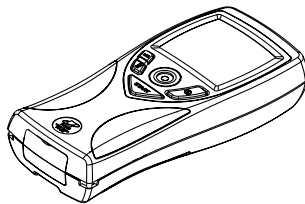

Main unit

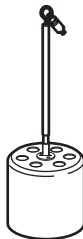

No. 3 rotor



No. 1 rotor



No. 2 rotor

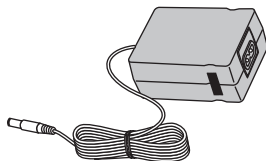

AC adapter (option)



IEC LR6
(size AA)
batteries



No. 3 cup



Rotor extension

Top view

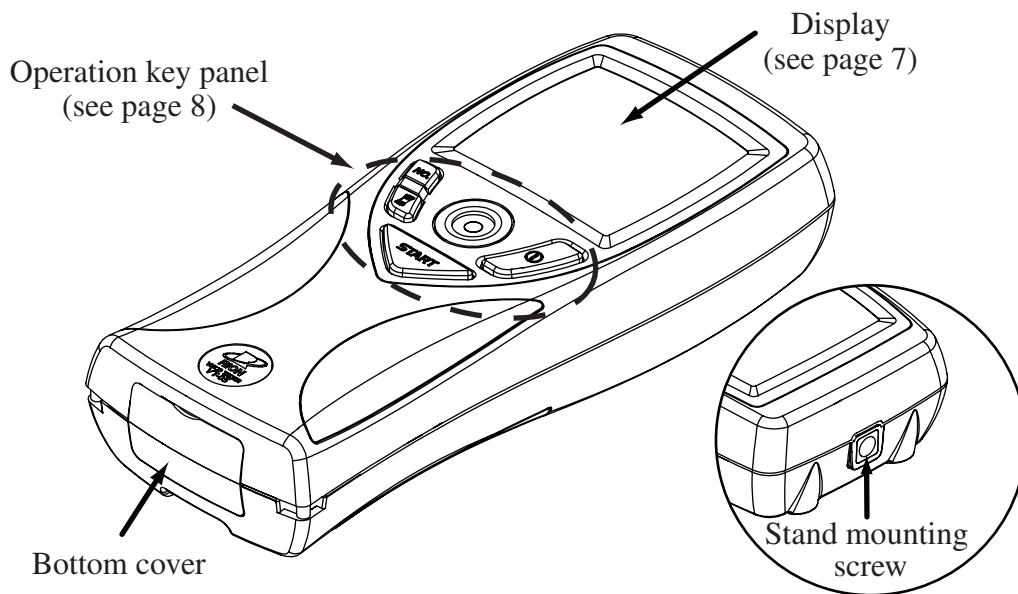

Rear view

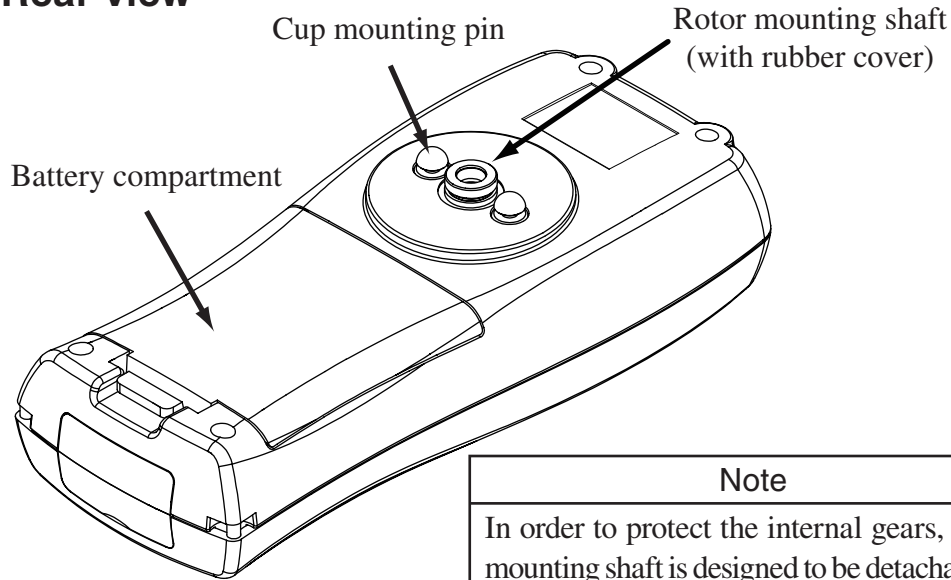

Note

In order to protect the internal gears, the rotor mounting shaft is designed to be detachable. Like the rotor, the screw thread is left-handed, which may lead to loosening when removing the rotor. If this happens, lightly tighten the shaft again.

Bottom view

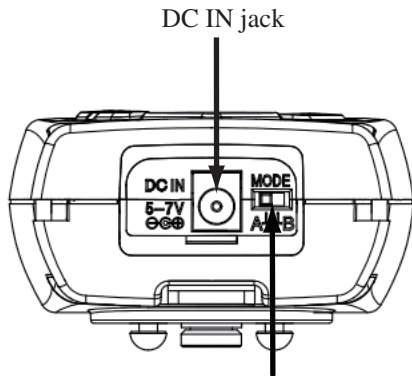

DC IN jack

MODE selector switch

A: Normal operation

B: The motor starts to turn at the same time
the power key is set to ON.

Display

VT-05 example

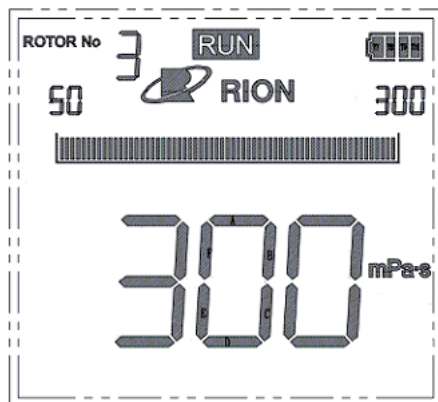

VT-06 example

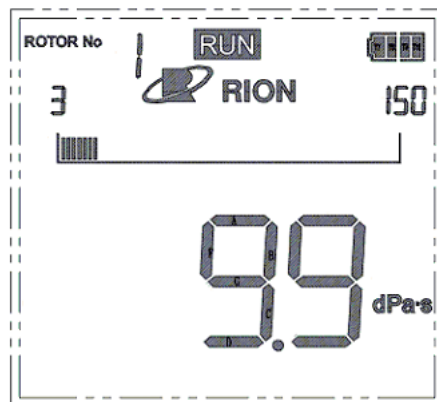

Operation key panel

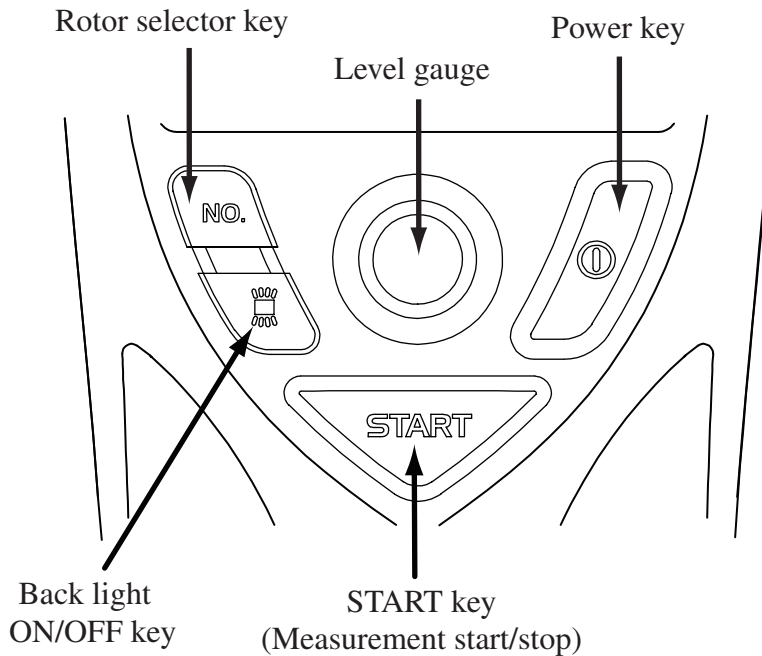

Power key

Turns power to the unit on and off. The key must be held for at least 1 second to take effect.

START key

Press to start or stop the measurement.

Back light ON/OFF key

Turns the backlight on and off. The backlight is automatically turned off when there is no key activity for a certain period.

Rotor selector key

Press to select the rotor number.

Preparations

Power Supply

Using an AC Adapter (Option)

To power the unit from an AC adapter, plug the output cable from the adapter into the DC IN jack on the viscotester and plug the AC adapter into an AC outlet rated for 100 V to 240 V AC.

 Caution
To prevent the risk of electric shock, always connect the adapter output cable to the viscotester first, and only then plug the AC adapter into the AC outlet.
Use a genuine AC adapter (VA-05J)

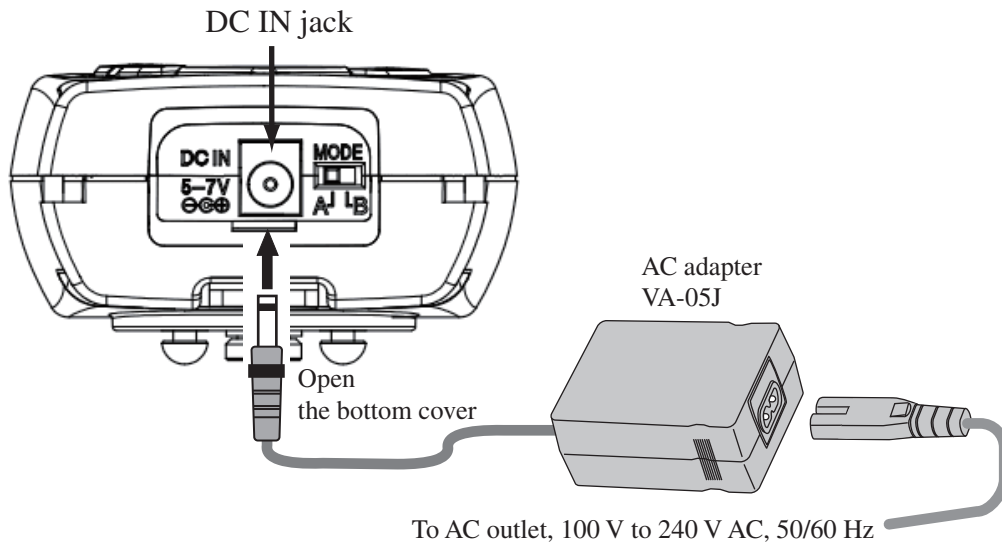

Using Batteries

When operating the unit on battery power, be sure to set the selector switch inside the battery compartment to the correct position for the type of batteries in use (alkaline batteries or nickel-metal hydride rechargeable batteries)

Alkaline battery (ALKALINE)-
Nickel-metal hydride rechargeable battery
(NI-MH) selector switch

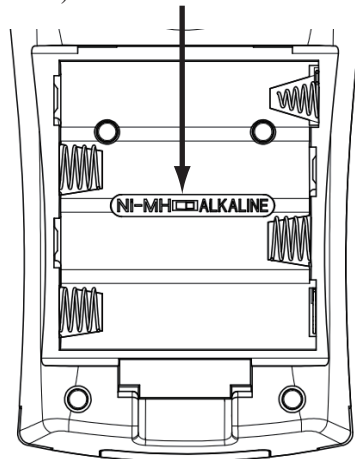

Checking the battery voltage

During viscosity measurement, check the battery status on the display. The number of black segments will decrease as the batteries get used up (4 steps).

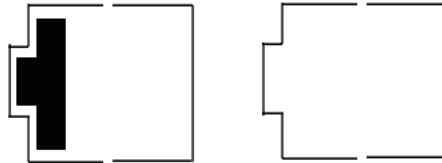

When battery status indicator is down to 1 segment:

Replace the batteries as early as possible with a fresh set.

When battery status indicator shows no black segments:

Measurement cannot be performed. Replace the batteries with a fresh set.

Inserting the batteries

1. Remove the battery compartment lid as shown below.
2. Insert four IEC LR6, size AA batteries, paying attention to the polarity as shown below.
3. Replace the cover.

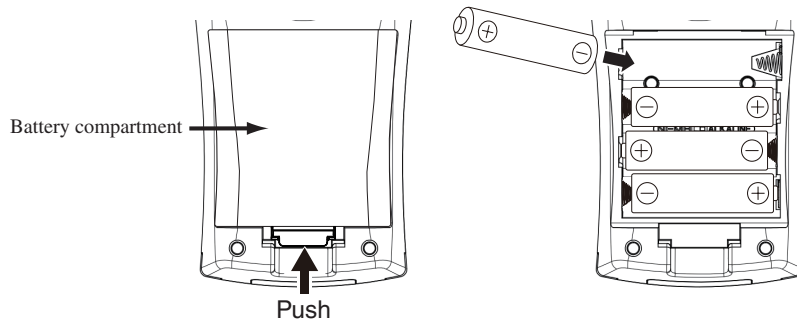

Push the latch in the arrow direction and then lift up to open the lid

⚠ Caution
Do not insert the battery conversely.

Attaching the Rotor and Cup (VT-05)

Select a suitable rotor for the viscosity of the sample fluid (see page 25), and insert the rotor into the cup. Taking care that the rotor does not fall out, raise the cup, engage the oval hole in the handle on the cup mounting pin of the main unit, and rotate it to the right to lock. Turn the cup again to the right to verify that it is securely fastened.

After that, screw the rotor into the rotor mounting shaft.

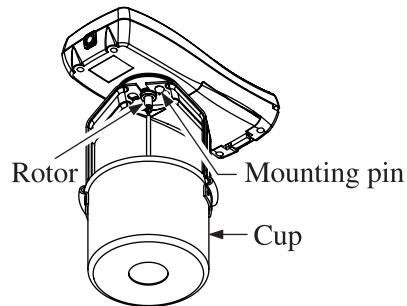

Note

- If you do not know the viscosity of the sample fluid, perform measurement using rotors in the following order: No. 3 rotor, No. 5 rotor, No. 4 rotor.
- Because this is a left-hand (reverse) screw thread, you must turn the rotor counterclockwise to screw it in.
- Check the blue rubber section of the rotor mounting shaft does not touch the case of the unit. Otherwise the correct measurement may be impossible.
- To detach the rotor, hold the blue rubber section of the rotor mounting shaft with your fingers and turn the rotor clockwise.
- To remove, detach the rotor first and then remove the cup.

Attaching the Rotor (VT-06)

Select a suitable rotor for the viscosity of the sample fluid (see page 29), and screw the rotor into the rotor mounting shaft.

Note

- If you do not know the viscosity of the sample fluid, perform measurement using rotors in the following order: No. 2 rotor, No. 1 rotor, No. 3 rotor.
- Because this is a left-hand (reverse) screw thread, you must turn the rotor counterclockwise to screw it in.
- Check the blue rubber section of the rotor mounting shaft does not touch the case of the unit. Otherwise the correct measurement may be impossible.
- To detach the rotor, hold the blue rubber section of the rotor mounting shaft with your fingers and turn the rotor clockwise.

Preparing the Sample Fluid

VT-05

When using cup A (no cutout), fill the cup with sample fluid to the upper brim. When using cup B (with cutout), insert the cup into the sample fluid up to the upper brim. For both cups A and B, the indication of the sample amount is about 460 mL.

VT-06

Choose the rotor according to the viscosity of the sample fluid. Depending on the rotor, the required cup size also changes. For No. 1 and No. 2 rotors, use a JIS 300 mL beaker* filled with about 350 mL of sample fluid. For the No. 3 rotor, use the No. 3 cup filled with about 150 mL of sample fluid.

*The actual capacity of the JIS 300 mL beaker is about 420 mL.

Note
Adjust the volume of the sample fluid so that it does not overflow when the rotor is inserted in the cup or beaker.
When measuring fluid with a low viscosity, the fluid may spill when the rotor is activated. Adjust the fluid first to a suitable level.
A JIS 300 mL beaker is not supplied. Please use a commercially available product.

Measurement

1. Hold the viscotester in one hand or mount it to the optional stand (VA-04). Use the level gauge on the unit to verify that the unit is approximately horizontal.
2. Place the rotor in the center of the cup or beaker and fill in sample fluid so that it comes to about the center of the fluid mark on the rotor.
3. Hold down the power key until the power is set to on (at least 1 second).
4. Use the rotor selector key to select the correct rotor number.

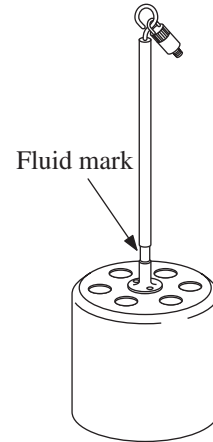

5. Press the START key.

The indication “RUN” appears on the display and the rotor starts to turn. Hold the unit steady until the viscosity indication has stabilized. When a stable value has been obtained, press the START key again. The rotor stops turning, and the measurement value remains on the display for easy reading.

6. When measurement is completed, hold down the power key until the power is set to off (at least 1 second).

*** About power swing**

When the rotor starts to turn, temporary overload may cause a so-called power swing condition where the rotor cannot turn properly. In such a case, the indication “FAIL” is shown on the display, the rotor is stopped, and then started up again.

Important

If the measurement value is below the measurement range for the respective rotor, the indication “UNDER” will be shown in the left part of the display under the bar graph. If the measurement value exceeds the measurement range, the indication “OVER” will be shown. Select the correct rotor so that these indications do not appear.

Note

Battery life will differ depending on the sample fluid being measured, but a rough estimate is shown below.

Conditions:

- IEC LR6 (size AA) alkaline batteries
- Measurement time 100 seconds per measurement
- Sample fluid viscosity near maximum of respective rotor measurement range

Battery life:

VT-05 approx. 600 measurements

VT-06 approx. 300 measurements

The unit cannot be shut the power off by the power key while the rotor is turning.

Applied part

Rotor extension (only for VT-06)

The supplied foldable rotor extension consists of three 30 cm rods joined by rings. The combined length is 90 cm. When wishing to use the extension at a length of 30 cm or 60 cm, open the connector rings with a pair of pliers, remove the desired number of elements, and rejoin the extension rods. Be sure to close the rings fully again, to prevent the extension from getting detached during use.

Attach the end with the male thread to the viscotester and the end with the female thread to the rotor.

Note that both are left-hand (reverse) screw threads, so you must turn the parts counterclockwise to screw them in.

When measuring a fluid with high viscosity, the joint will look as shown in the illustration, but this does not affect the measurement.

The rotor extension rods are made of stainless steel.

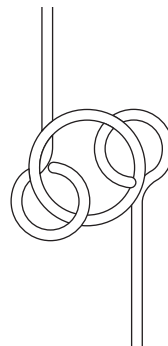

Specifications

VT-05

Measurement range

No. 4 rotor: 2 to 33 mPa•s (resolution: 0.1)

No. 5 rotor: 15 to 150 mPa•s (resolution: 1)

No. 3 rotor: 50 to 300 mPa•s (resolution: 1)

Sample fluid capacity Approx. 460 mL

(With supplied accessories cup A or cup B)

Measurement accuracy

Within $\pm 5\%$ of each rotor's maximum measurement range

* Calibrated according to JIS Z 8809:2011 standard liquids for calibrating viscometer

Rotor speed 62.5 rpm

Max. continuous measurement time per measurement

100 s

Display value hold function

Value at end of measurement is retained

Backlight function

Switchable backlight

Time until auto-off:

60 s (when rotor is not operating and unit is powered from batteries)

Auto shutdown function (when an AC adapter is not used)

If rotor is not turning and no controls are operated for 5 minutes, power is automatically shut off

Resume function

Last selected rotor number setting is retained during power-off

Ambient conditions for use

5°C to 35°C, 10% to 90%RH (no condensation)

Power requirements	Alkaline batteries LR6, Ni-MH rechargeable batteries, or AC adapter VA-05J (5 V to 7 V : rated voltage 6 V)
Current consumption	approx. 150 mA (at maximum torque)
Battery voltage check	Displaying battery status (4 steps)
Dimensions	175 (H) × 77 (W) × 45 (D) mm (maximum) 175 (H) × 77 (W) × 40 (D) mm (without protruding parts)
Weight	Approx. 260 g (without batteries)

Supplied accessories

No. 3 rotor (dia. 45 × 47 × 160 mm)	SUS304	1
No. 4 rotor (dia. 78 × 46 × 159 mm)	A1050 (alumite)	1
No. 5 rotor (dia. 61.2 × 36 × 149 mm)	A1050 (alumite)	1
Cup A (no cutout) (dia. 92 × 76 mm)	A1050 (alumite)	1
Cup B (with cutout) (dia. 92 × 76 mm)	A1050 (alumite)	1
IEC LR6 (size AA) battery		4
Instruction manual		1
Viscosity measurement guide		1
Inspection certificate		1

Optional accessory

AC adapter	VA-05J
Stand	VA-04

VT-06

Measurement range (based on combination with the cup specified below
“Sample fluid capacity”)

No. 3 rotor: 0.3 to 13 dPa•s (resolution: 0.1)

No. 1 rotor: 3 to 150 dPa•s (resolution: 1)

No. 2 rotor: 100 to 4000 dPa•s (resolution: 10)

Sample fluid capacity

No. 1 and No. 2 rotor

Approx. 350 mL (with JIS 300 mL beaker)

No. 3 rotor Approx. 150 mL (with No. 3 cup)

Clearance between rotor end and cup bottom: about
15 mm

Measurement accuracy and reproducibility

Measurement accuracy

$\pm 10\%$ ± 1 digit of indicated value

Reproducibility	$\pm 5\%$ * Calibrated according to JIS Z 8809:2011 standard liquids for calibrating viscometer * The rounding error resulting from resolution occurs
Rotor speed	62.5 rpm
Max. continuous measurement time per measurement	100 s
Display value hold function	Value at end of measurement is retained
Backlight function	Switchable backlight Time until auto-off: 60 s (when rotor is not operating and unit is powered from batteries)

Auto shutdown function (when an AC adapter is not used)	If rotor is not turning and no controls are operated for 5 minutes, power is automatically shut off
Resume function	Last selected rotor number setting is retained during power-off
Ambient conditions for use	5°C to 35°C, 10% to 90%RH (no condensation)
Power requirements	Alkaline batteries LR6, Ni-MH rechargeable batteries, or AC adapter VA-05J (5 V to 7 V : rated voltage 6 V)
Current consumption	approx. 250 mA (at maximum torque)
Battery voltage check	Displaying battery status (4 steps)
Dimensions	175 (H) × 77 (W) × 45 (D) mm (maximum) 175 (H) × 77 (W) × 40 (D) mm (without protruding parts)
Weight	Approx. 260 g (without batteries)

Supplied accessories

No. 1 rotor (dia. 24 × 53 × 166 mm)	SUS304	1
No. 2 rotor (dia. 15 × 1 × 113 mm)	SUS304	1
No. 3 rotor (dia. 45 × 47 × 160 mm)	SUS304	1
No. 3 Cup (dia. 52.6 × 75 mm)	SUS304	1
Rotor extension (in a tube) (900 mm; 300 mm × 3)	SUS304	1
IEC LR6 (size AA) battery		4
Instruction manual		1
Viscosity measurement guide		1
Inspection certificate		1

Optional accessory

AC adapter	VA-05J
Stand	VA-04

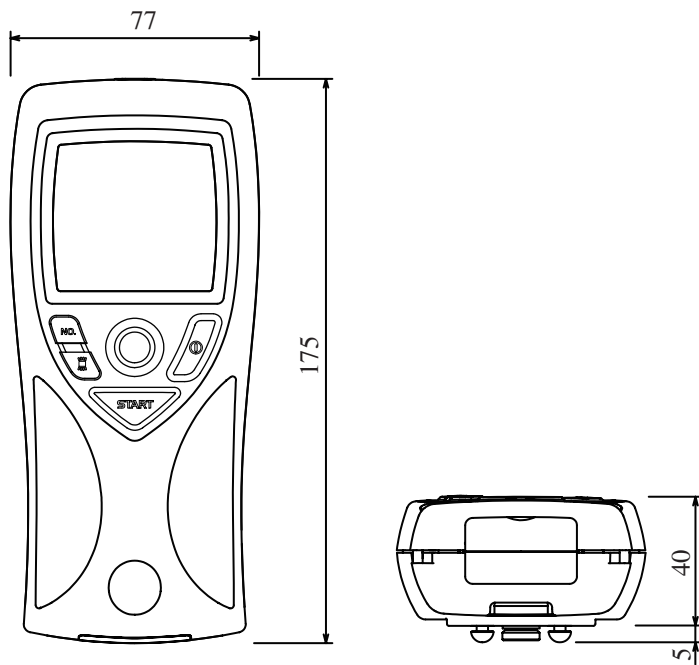

Unit: mm

Dimensional Drawings

Distributor RION CO., LTD.
3-20-41 Higashimotomachi, Kokubunji, Tokyo 185-8533, Japan

Manufacturer KYOSAITHECNOS CO., LTD. KORIYAMA OFFICE
214 Doba, Kooriyama City, Fukushima 963-8824, Japan